



## **COLLECTOR INSTRUCTIONS MANUAL**

**WUNDER ALS 3010 models**





## 1.1 Solar Energy

### Benefits of Solar Energy

The Sun has been providing the Earth with its light and heat for billions of years and has facilitated life on Earth. We have been utilising its energy and heat for many centuries. It heats up our living areas efficiently during the summer. But in the winter alternatives for heat and energy production are used such as wood, coal, liquid and solid fuel. Utilising the Sun's energy will mean that the Earth has a huge stock of potential energy. To use this resource effectively, the thermal energy sector has been developing solutions such as solar thermal technology. One of the most important applications of solar energy is heating by the use of solar thermal flat-collectors. The economic benefits that arise from these kinds of collectors, such as cost-saving are not just dreams. Indeed, it is a proven fact that heating using solar thermal systems have economic benefits when using the correct solar thermal collectors. We at Solimpeks believe that investing in solar energy is the most useful investment both for today and for our future generations.

### Benefitting from Solar Energy by Using Solar Collectors

Different variables determine whether the solar collectors can maximise useful energy from the Sun. Here the most important factor is the abundant supply of solar energy, and the other variables include the collector types, installation directions and slopes.

The solar collector, Wunder, is one of the most efficient products in its class, it is based on Sol – Titanium coated Aluminium absorbers. This absorber gets the best possible absorption of solar rays and also has a very low level of thermal radiation emittance. The heat carrier fluid flows in the copper pipes which are welded to the absorber sheet by laser welding. The Absorber's heat is reflected to the heat carrier fluid by copper pipes. The Absorber is covered by the collector body which is well insulated to withstand high temperatures. The Collector's heat losses are decreased to minimal levels by using high quality insulation materials. This rock wool mineral insulation material can endure high level temperatures. The collector's face is covered by a solar safety glass which is low iron tempered in order to lower the emittance (reflection losses). The glass and collector face is covered by EPDM material and it is also fixed to the collector case by another aluminium frame. The flexible connection pipes (supplied with Wunder collectors) have a real advantage as it is easy to install up to seven collectors to a battery. The sensor stick is mounted on the outlet of the solar system to control the systems temperature. The collector case has ventilation holes to prevent condensation that can occur within the collector. The purpose of these ventilation holes is to allow excess water and steam to escape, thus condensation is avoided.

### COLLECTOR CASE

The collector case is produced from aluminium by Solimpeks solar energy systems. The aluminium used as raw material is 6603-60 (AlMgSi05) (AA-USA). The collector case is

SOLIMPEKS ENERJİ SAN. VE TİC. A.Ş.

[www.solimpeks.com](http://www.solimpeks.com) / [info@solimpeks.com](mailto:info@solimpeks.com)

Fezî Çakmak Mah. 10753 Sok. No:3 42050 Konya / TÜRKİYE  
Tel:+ 90 332 444 06 02 Faks:+ 90 332 444 06 08

produced with a frame which is a user friendly both in terms of mounting and dismantling the system. Wall thicknesses both for the case and frame are all according to DIN EN 12975 -1 and 2. Collector case is made of aluminium which is electrostatic painted with Ral 9005 matt black powder paint and then oven baked. The use of this technique ensures the system is highly protected against all natural conditions. Also taken into consideration is the possible thermal expansions that could occur on the glass, hence the glass is set up with an optional space during casing and the collectors are produced to be able to work properly in all regions of the world.

### **CASE - TECHNICAL SPECIFICATIONS**

Specific gravity	: 2,70 g/cm <sup>3</sup>
Gravitation endurance	: 15,5 (at 24C <sup>0</sup> Kg/mm <sup>2</sup> )
Flow endurance	: 12 (Kg/mm <sup>2</sup> )
Hardness	: 60-65 Brinell (HB) Kg/mm <sup>2</sup> )
Expansion coefficient	: 23*10(200-100C <sup>0</sup> )/C <sup>0</sup>
Profiles	: DIN 1748 Tolerance
Elasticity particle	: 6900 Kg/mm <sup>2</sup>
Extension	: %8 Delta L/L*100 (50 mm Length)
Cutting Endurance	: 11,5 Kg/mm <sup>2</sup>
Paint thickness	: 60-80 Microns

### **COLLECTOR INSULATION**

Heat loss can occur on the bottom and the sides and this can be decreased by using insulation material. Insulation material is designed to be resistant against high temperatures of up to 650°C within the collector. The insulation material must be of a high quality in order to withstand these high temperatures. In addition, this insulation material with its high density does not produce gas, thus the transparent cover's solar conductivity is not affected.

Mineral rock wool, a high quality insulation material, is used inside the collector which touches the absorber sheet and also has endurance against high temperatures. The insulation material rock wool is also water-resistant against water which could accumulate in the collector.

### **TRANSPARENT COVER – THE GLASS**

The glass used in Solimpeks collectors has the thickness of 4mm and has the tolerance of  $\pm 0,2\text{mm}$ . The density of the glass is 2,5 g/cm<sup>2</sup>. To increase the solar conductivity of the glass, the iron oxide level is lowered. The prismatic shape of the glass brakes the solar rays which come inclined in the morning and evening, and makes the solar rays vertical with this prismatic design, this ensures maximum efficiency. The other important characteristic of the glass is has high endurance. During the transportation and mounting process, to prevent the

highly risk of breakage, Solimpeks uses tempered glass which can also be described as safety glass. This type of tempered glass is very strong and brakes very rarely. Should the tempered glass brake, it breaks into small pieces thus reducing the risk of harm.

### Assembly of Glass and Case

The sides of the glass are wrapped with EPDM before being assembled onto the frame. EPDM is used for leak proofing and it is resistant to 150 degrees and to the aging effect of the sun. Silicone is applied between the EPDM and glass. Before assembling, the expansion of the glass must be taken into consideration. Therefore, all the possible negative effects of expansion are neutralized by leaving enough room between the glass and the case for expansion. Regular rain cleans the glass. In conditions where there is a of lack of rain, the glass must be cleaned. It can be cleaned by ordinary cleaners and water. It should be remembered that the cleaner the glass the more efficient the collector is.

### WUNDER ALS models cross - section

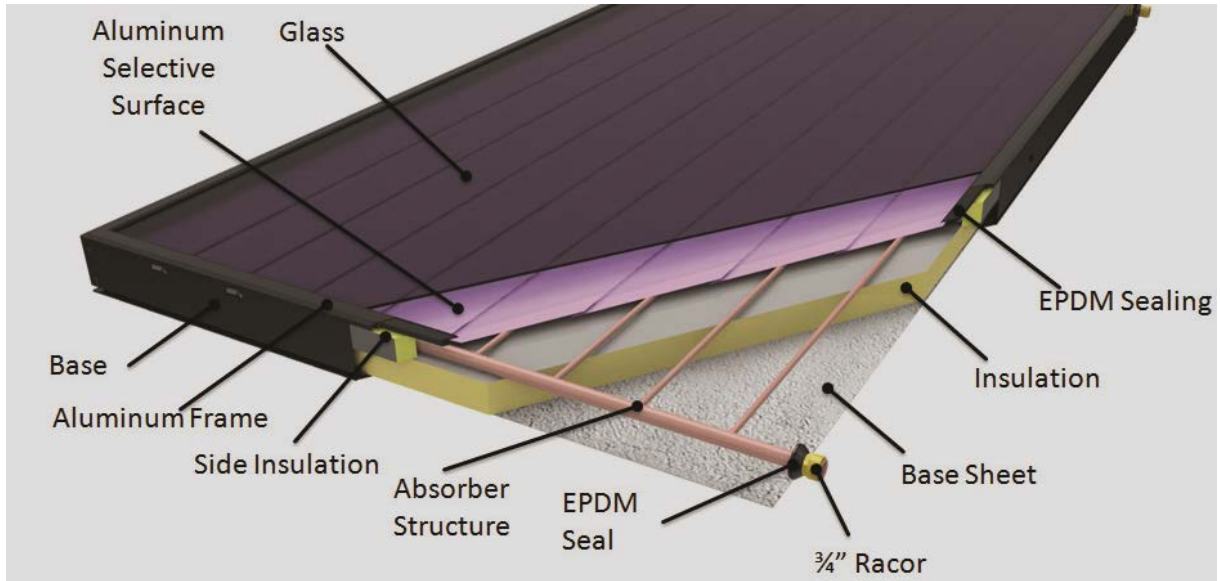

### Terms & Conditions related to the attention of the consumer:

The product guarantee granted by Solimpeks Solar Energy Systems Co. does not cover the damage caused by usage of the collector in inappropriate conditions.

1. Get the guarantee certificate approved by the seller.
2. Guarantee Certificate is invalid if:
  - (i) Guarantee certificate is not stamped and approved by an authorised person.

- 
- (ii) The certificate is damaged, defaced, deformed and the serial number is erased.
3. Product must be used exactly as instructed in the manual. In case of an incompliant usage the guarantee terms will be invalid.
  4. Any damages sustained before the product arrives is not covered by the guarantee.
  5. Guarantee is invalid when damage caused is by freezing, which is due to lack of appropriate anti-freeze use by the consumer when it is necessary to do so.
  6. The breakage of glass because of the external factors invalidates the guarantee.
  7. Any service by other than authorized personnel will invalidate the guarantee.
  8. The lack of regular maintenance and controls invalidates the guarantee.
  9. Possible damage caused while the liquid in the system is being evacuated with high pressure systems is not covered by the guarantee.
  10. The damage caused by the incorrect connection of pipes invalidates the guarantee.
  11. The damage caused by the incorrect installation of the tank, collector and mounting kits invalidates the guarantee.
  12. The delivery of the guarantee certificate is under the responsibility of the technical service, seller or branch.

## **TERMS OF WARRANTY**

1. Warranty time begins with the invoice date and contains different time periods for different types of products.
2. All the defects and errors occurred by Solimpeks during manufacturing process are under guarantee terms.
3. The products manufactured by Solimpeks have a limited time of repair under warranty terms, this limited repair time is 30 working days.
4. The products imported or traded by Solimpeks are not under these warranty terms, Solimpeks just reflects the same warranty terms and conditions of the original supplier.
5. If the defects are not possible to repair, Solimpeks replaces the product with a new one.
6. The defects and errors occurred during the project process, installation, transportation and poor finishing are not under these warranty terms.
7. Solimpeks guarantees the collectors for a period of 10 years and guarantees the boilers for 5 years.

## **INVALIDATES WARRANTY TERMS**

1. The defects and errors during project, installation and poor finishing.
2. The defects and errors during transportation.
3. The defects and errors occurred by and during open loop installation of the system, such as corrosion and freezing of the system.
4. The defects and errors occurred by not protecting the system against freezing on the closed loop applications.
5. The defects and errors occurred by mounting or repairing the system without the authorized dealer or service.
6. Breakage of the glass.
7. Natural disasters like fire, calamity, earthquakes, hail etc.
8. The defects and errors occurred by incorrect usage from the consumer.
9. The defects and errors occurred by antifreeze liquid leakages such as corrosion and sedimentation.
10. Chemical and physical damage caused by other equipment while installing the system.
11. Any defects and errors on the warranty letter such as an unconfirmed warranty letter or any amendments and changes on it.
12. Any claim regarding to the condensation occurred in the collector.

### **MANUFACTURER COMPANY**

Solimpeks Enerji San. ve Tic. A.Ş.

Fevzi Çakmak Mah. 10753 Sok. No : 3

42050 – Karatay / KONYA / TURKEY

Tel: 0332-444 06 02 / Fax: 0332-444 06 08

[www.solimpeks.com/](http://www.solimpeks.com/) / [info@solimpeks.com](mailto:info@solimpeks.com)

### **CUSTOMER**

Name / Surname:

Tel :

Address: .....

.....

.....

### **SELLER COMPANY**

Date / Signature / Stamp

### **PRODUCT**

Brand:

Model:

Serial No :

Delivery date:

**SOLİMPEKS ENERJİ SAN. VE TİC. A.Ş.**

[www.solimpeks.com/](http://www.solimpeks.com/) / [info@solimpeks.com](mailto:info@solimpeks.com)

Fevzi Çakmak Mah. 10753 Sok. No:3 42050 Konya / TÜRKİYE  
Tel:+ 90 332 444 06 02 Faks:+ 90 332 444 06 08

---

**WARRANTY LETTER WILL BE SENT TO THE MANUFACTURER COMPANY**

I have read and accepted all the warranty terms and conditions.

**Must be paid attention to:**

The warehouse must protect the collectors from external conditions, such as the weather.

The collector must not be stocked in humid places.

**Must be paid attention to during installation:**

- All precautions must be taken before the installation since the area is high or sloped.
- Check the installation surface before installing.
- During the installation construction conditions, technical situations and local regulations must be obeyed.
- If the collector will be installed on the roof, it is crucial to installation that the collectors are installed as far away as possible from the chimney so that smoke emitted from the chimney can be avoided.
- Trees, high buildings, chimneys etc. mustn't shade the collectors.
- All the screws and bolts must be tightened firmly.
- **Transportation of the collectors, boilers and mounting kits to the installation area.**
  - The goods mustn't be unpacked before the installation under any circumstances.
  - Collectors mustn't be transported leaning vertically.
  - Collector must be stacked parallel to the floor (max. 7 pieces).
  - Collectors must be fixed securely during transportation and nothing must be loaded on top of them.
  - Collectors must not be dragged.
  - The boilers must be in the packaging until ready for installation.
  - All accessories must not be unpacked until installation.
- **Carrying the collectors and other equipment to the installation point.**
  - If the collectors are being pulled up by a rope, collectors must be pulled up one by one.
  - Collectors must be pulled up in a fixed position.
  - If the boiler is being pulled up with a rope, it mustn't be unpacked and must be fixed by two points.

- If the mounting kits are being pulled up, profiles must not be unpacked.
- Anyone who pulls the materials up, must secure themselves.
  - Anyone who hasn't secured themselves mustn't attend the installation.
- The systems must not be installed in adverse weather conditions such as snowy, rainy and windy weather.

#### • Preparing the surface for mounting kits

The direction and angle must be specified. Collectors must be faced towards the South.

The verification of the direction must be done by a compass.

The angle of the collector must be at the average latitude of the city for all year usage. If the system is going to be used only in the summer, the angle must be 15 degrees lower than the latitude, in winter 15 degrees higher.

It has be observed that the collectors are most productive at the angles between 30° and 40°.

There must be at least a 10 cm gap between the bottom of the collector and the surface to minimize the impact of the wind.

The installation area must not be shaded in winter between 09.30 and 16.00.

## WUNDER ALS

### Technical Specifications

Spesification / Type	Wunder ALS 3010
Dimensions	2427x 1218 x 90 mm
Casing Material	Electrostatic Painted Aluminium Case
Weight	54 kg
Sealing Material	EPDM & Silicone & ALUMINUM FRAME
Gross Area	2.97 m <sup>2</sup>
Aperture Area	2.76 m <sup>2</sup>
Absorber Area	2.76 m <sup>2</sup>
Absorber Material	Almecco-Tinox Highly Selective Aluminum
Thickness	0,40 mm
Absorptance	%95
Emittance	%4



Welding Method	Laserwelding
Heat Carrier Volume	1.57 liter
Diameter of Absorber Tube	8,0 mm / 10 mm / 12.7 mm
Absorber Tube Wall Thickness	0,45 mm
Diameter of Header Tube	18 mm / 22 mm / 24 mm
Header Tube Wall Thickness	0,70 mm
Number of Tubes	12
Tube pitch (mm)	95 mm
Glass Material	Low Iron Tempered Glass
Transmittance of Glass	%91
Thickness of Glass	4 mm / 3.2 mm
Insulation Material	Rock wool
Thermal Conductivity	0.037 W/(mK)
Heat Capacity of wool	0.84 kJ/(kgK)
Density of wool	40 density
Thickness of wool	40 mm
Stagnation Temperature at 1000 W/m <sub>2</sub> and 30 °C	203 °C
Max. Operation Pressure	10 bar
Test Pressure	15 bar
Nominal Flow Rate	120 liter/h
Base Sheatting	Embossed - finished Aluminium
Mounting Mode	Inroof, onto-roof, flat roof

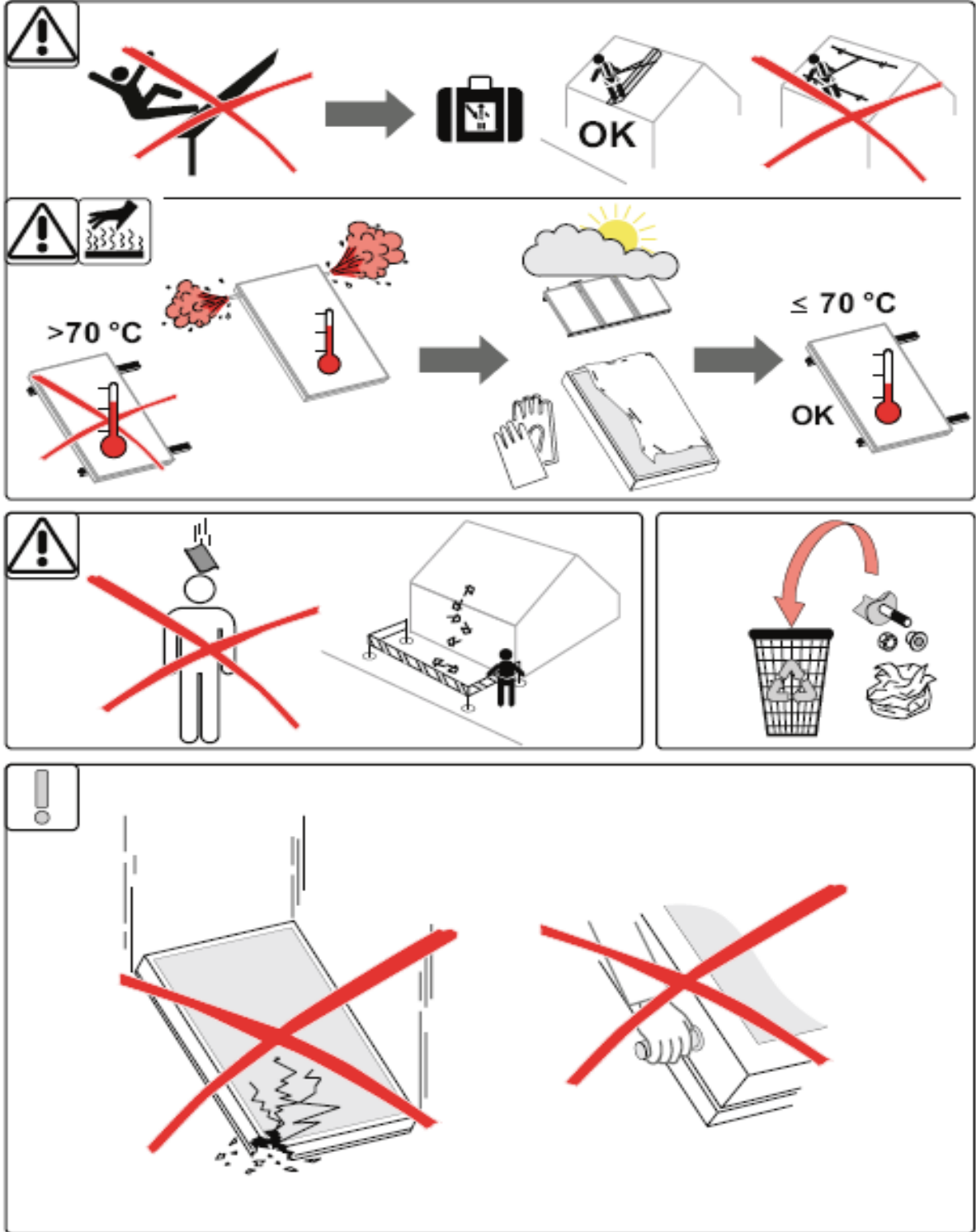

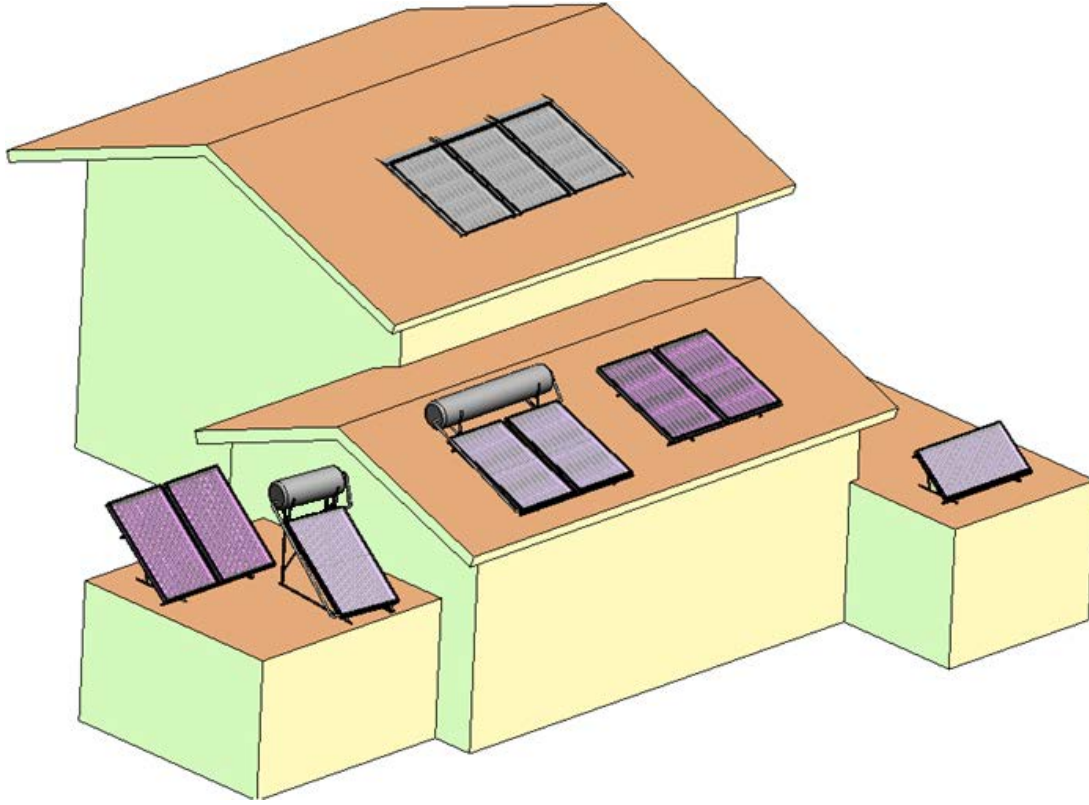

### **Slope and direction of the collector on the roof**

To get the best efficiency from the solar collector, it must be mounted at the right direction and slope. Both the slope angle and azimuth angle must be calculated before and while mounting the collector on the roof.

#### **Slope angle $\alpha$**

Slope angle  $\alpha$  is the angle between the collector and horizontal (x) axis. The absorber used in the collector can get the most efficient energy when it is mounted absolutely vertically to the Sun's rays. The angle of the Sun's rays varies subject to hourly and seasonal changes. Hence the collectors must be directioned with the correct angle and slope. It is advised that the angles between 30 and 45 degrees are the most ideal angles to mount the collector.

#### **Minimum and Maximum Tilt Angle of the Collectors**

The collectors can be set as min. 15° and max. 60 ° angles on the flat roof installations.

#### **Azimuth angle**

Azimuth angle means the deflection of the collector axis from south direction. So the angle of the collectors direction to the south is zero (0). The axis of the collector should be positioned as close as possible to the south. This is because the Sun's rays are at their peak at noon. The deviation up to 45 degrees to the south can be accepted.

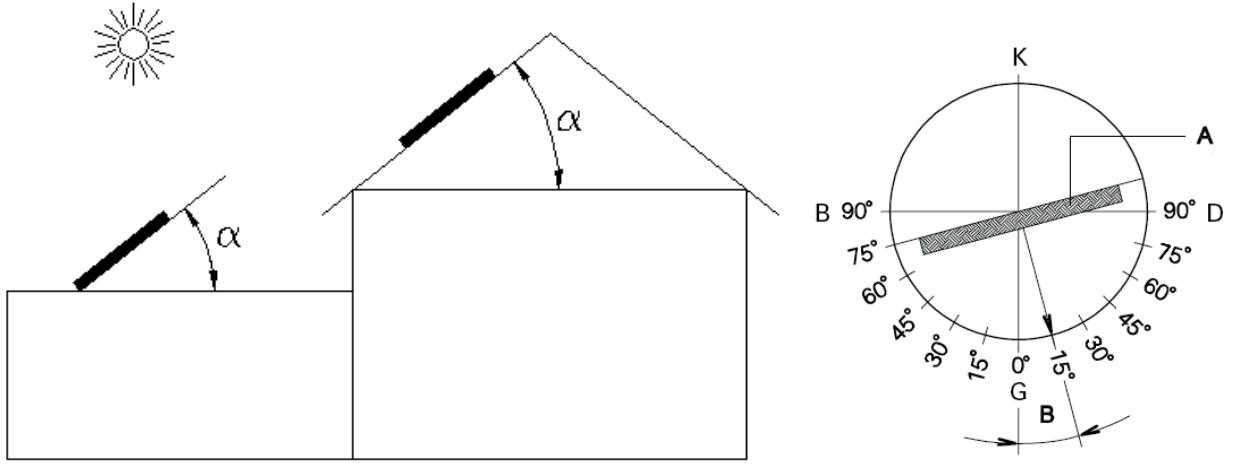

A- Collector deflection  
B- Azimut Angle

## FLAT ROOF

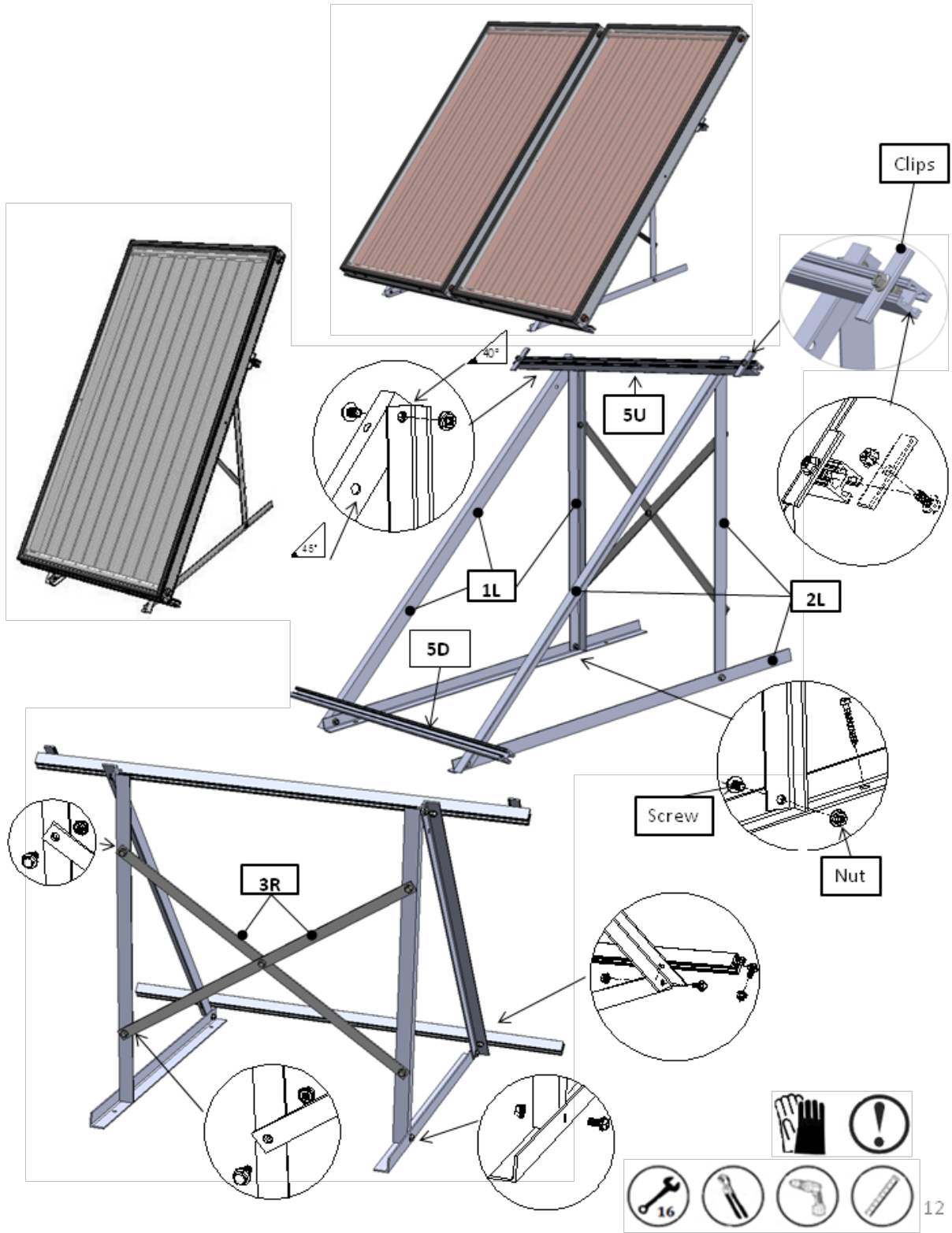

## Flat-Roof Dimensions

1 Collector 3010		
No	Unit	Dimensions
1L	1	3 screwed pieces of (1490 - 1190- 980) X 30 X 30 mm
2L	1	3 screwed pieces of (1490 - 1190- 980) X 30 X 30 mm
3R	1	2 screwed pieces of 980 X 30 X 5 mm
5U	1	1050 X 30 X 30 mm
5D	1	1050 X 30 X 30 mm
Screw	17	M10 X 20
Nut	17	M10
Clips	2	90 X 30

2 Collector 3010		
No	Unit	Dimensions
1L	1	3 screwed pieces of (1490 - 1190- 980) X 40 X 40 mm
2L	1	3 screwed pieces of (1490 - 1190- 980) X 40 X 40 mm
3R	1	2 screwed pieces of 1670 X 30 X 5 mm
5U	1	2100 X 30 X 30 mm
5D	1	2100 X 30 X 30 mm
Screw	19	M10 X 20
Nut	19	M10
Clips	4	90 X 30

## ONTO ROOF

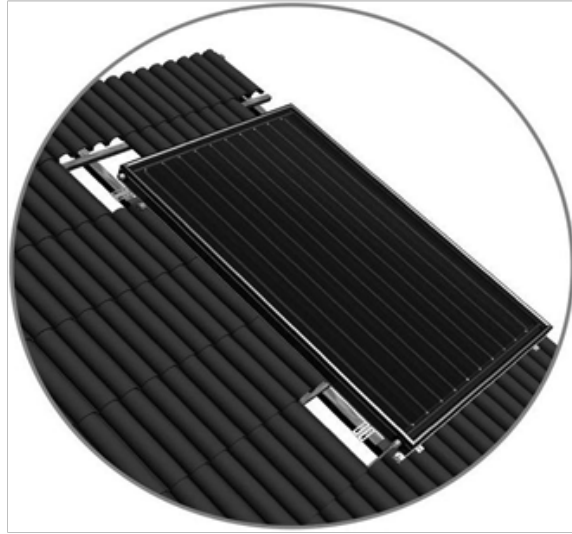
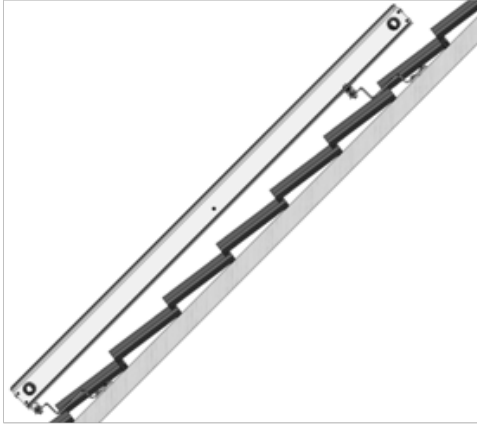

Part Name	Quantity	
	1 coll.	2 coll.
1 Straight Support	4	6
2 "Z" Support	4	6
3 8 x 60 Wood Screw	8	12
4 M8 x 12 Screw	8	12
5 M10 x 20 Screw	6	10
6 M10 Nut	6	10
7 Clips	2	4
8 Aluminum profile	1	1
9 Aluminum profile	1	1

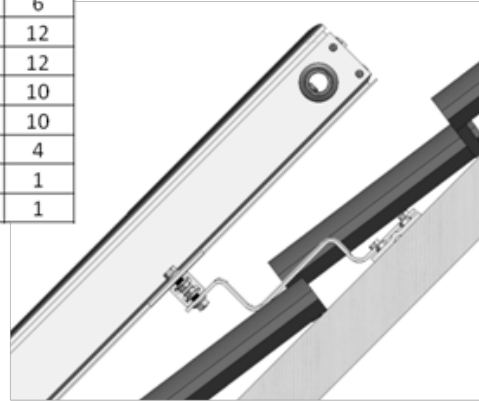
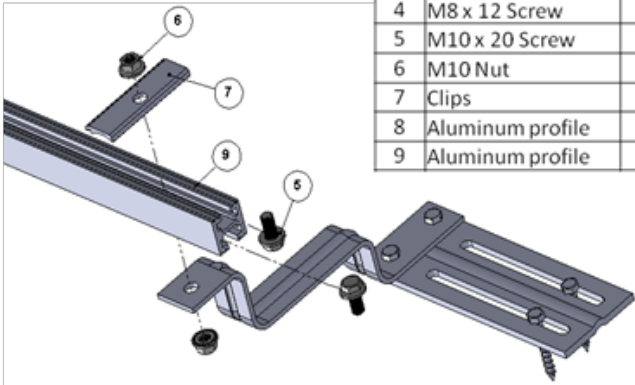

Aluminum profile dimensions (mm)		
Model	1 coll.	2 coll.
2510	1335 x 30 x 30	2670 x 30 x 30
2108	1150 x 30 x 30	2300 x 30 x 30
2008	1150 x 30 x 30	2300 x 30 x 30
1808	1050 x 30 x 30	2100 x 30 x 30

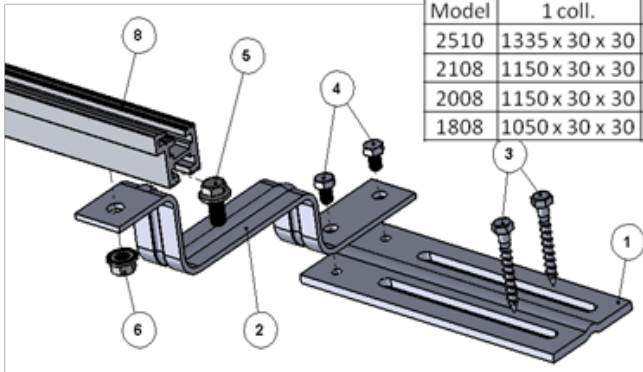



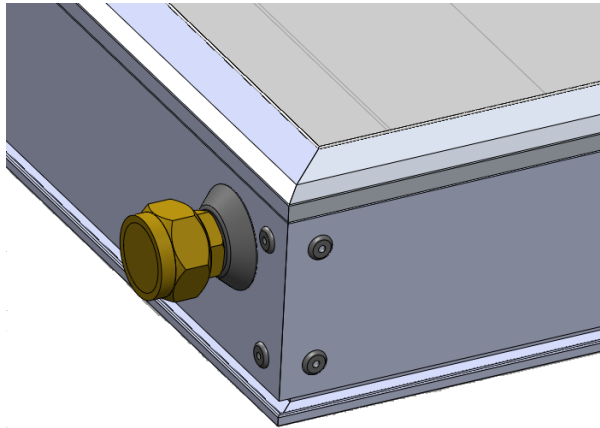
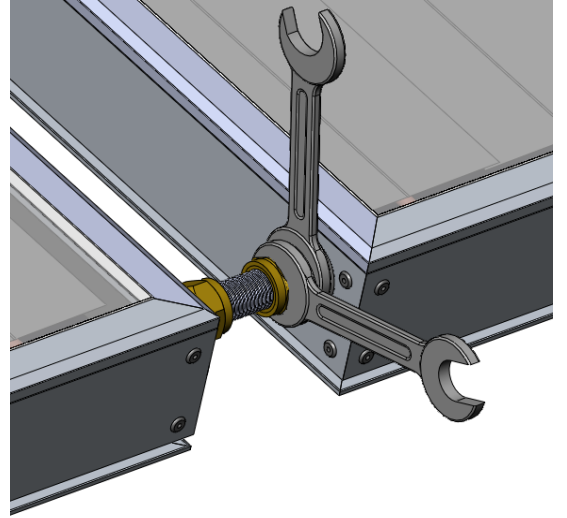
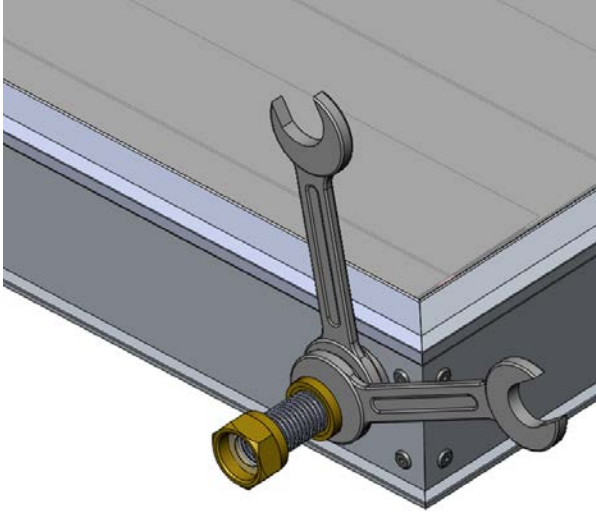
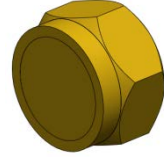
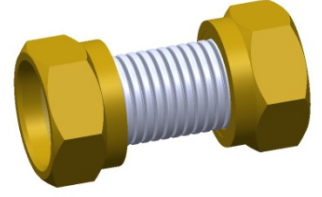
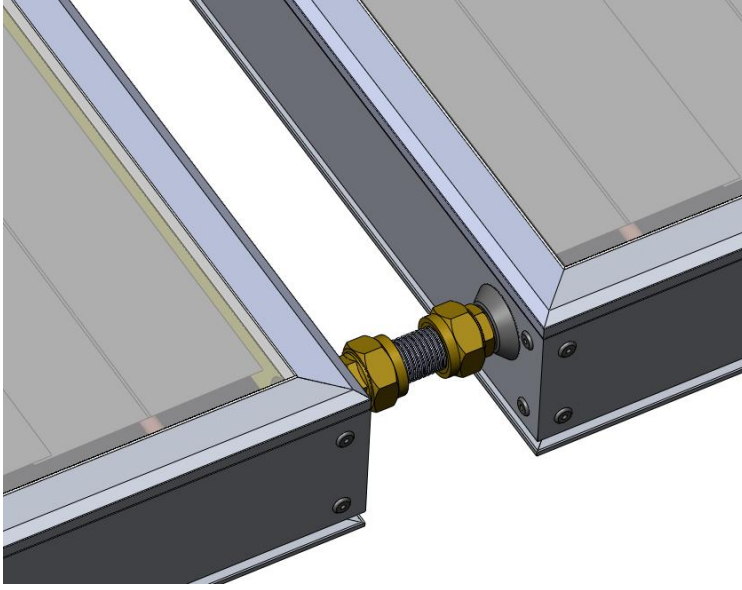



## **PERMISSIBLE (maximum) WIND AND SNOW LOAD**

The maximum snow load ( $s_k$ ) and main wind speed ( $v_m$ ) values the solar collector-support unit can withstand with the sloping roof supports are  $s_k = 0.66$  and  $v_m = 1.75$ , and so the system may only be installed in areas with values lower than these. With combined snow and wind loads the maximum strain for Wunder ALS collectors is  $2000 \text{ N/m}^2$ .

## **LIGHTNING PROTECTION**

ENV 61024-1

Protection of structures against lightning, Part 1: General principles (IEC 1024-1: 1990; amended).

## **CONNECTING THE COLLECTOR**

If a single collector is being installed, simply connect the solar liquid up-pipe to one of the lower accumulator inlets and the down-pipe to one of the upper inlets, blocking the other two inlets that are not in use. An installation where the up-pipe is connected to the lower right part and the down-pipe is connected to the upper right part is shown below.

For a dual collector installation, the collectors are to be connected so that the liquid flows crosswise. In addition to connecting the solar liquid up and down pipes to the lower inlets of the collectors (whether these are on the left or right hand side) and capping the other two inlets that are not in use, the two plates must also be connected to each other. An installation where the solar liquid up-pipe is connected to the lower right part and the down-pipe is connected to the lower left part is shown below.

Lastly, insert the sensor in the output elbow. To do this, make two cuts in the elbow cap\* through which the sensor passes and is inserted in the output elbow pipe. Finally, fit the cap on the output elbow pipe to fix the sensor to the pipe.

- For integrated supports, cut the cap to a length of 7 mm.

## Instructions about the coupling of the collectors to one another and the connection of the collector field to the heat transfer circuit, including dimensions of pipe connections for collector arrays up to 20 m<sup>2</sup>

The flow and return pipework can be passed through the roof either with a proprietary roof penetration tile or a Code 4 lead custom made roof penetration tiles. Ventilation tiles can sometimes be adapted for this purpose. Alternatively a silicon "dektite" can be used. Optional lead pipe flashing tile kits which can be adapted to suit most roof tiles are available. Any exposed elements of the roof penetration must be carefully sealed with exterior grade low modulus silicone.

Number of Solar Collectors	Single Pipe Length			
	Up to 6m	Up to 15m	up to 20m	up to 25m
to 5	Ø 15mm (DN12)		Ø 22 mm (DN 15)	Ø 22 mm (DN 20)
to 9	Ø 22 mm (DN15)	Ø 22 mm (DN20)	Ø 28 mm (DN25)	Ø 28 mm (DN25)

### IMPORTANT

All connections and joints must be resistant to temperature of up to 200°C and resistant to glycol.

During installation and servicing means for covering the solar collectors will be required to avoid burns. In direct sunlight, the solar collectors can reach temperatures of 200°C.

Note. It is recommended that you select the pipework in accordance with this table. If the system provides additional pressure loss (bends, valves, etc.), you should consider selecting pipe with larger diameter.

The collectors should be piped diagonally opposite corners as shown.

Note. The flow outlet can be either left or right exiting but ensure that the return is diagonally opposite).

- A Solar automatic air vent
- B Air vent fibre sealing washer
- C Isolation valve
- D Brass plug (fitted if air vent is located remote from the connector)
- E Flow manifold incl. stat pocket
- F Collector fibre sealing washer
- G Collector panel connections
- H Return connection fitting

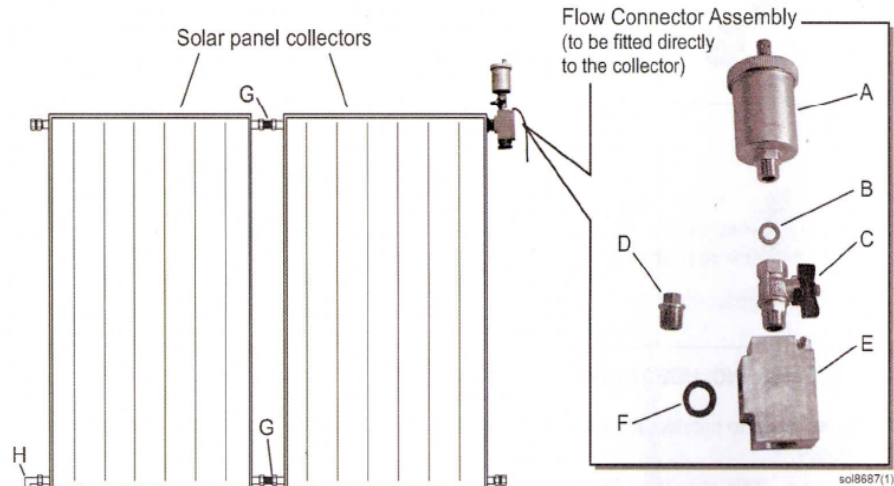

**For Pitched Roof Only: The Automatic Air Vent must be installed internally at a level above that of the collectors (i.e. within the pitch of the roof) to allow access for manual venting from within the roof space.**

The final part of the roof installation is the insertion of the silicon PT1000 Collector Sensor into its mounting pocket in the Flow Connector and feeding of the cable through or under the flow roof penetration and through the felt or timber sarking so that the sensor cable is visible in the loft space.

**Wiring run lengths and cross sectional areas for low voltage collector sensor wire:**

Lengths up to 50m: 0.75mm<sup>2</sup>

Lengths up to 100m: 1.5mm<sup>2</sup>

## MAINTENANCE

- Collector shading: Visually check for shading of the collectors during the day (mid-morning, noon, and mid-afternoon) on an annual basis. Shading can greatly affect the performance of solar collectors. Vegetation growth over time or new construction on your house or your neighbour's property may produce shading that wasn't there when the collectors were installed
- Collector soiling: Dusty or soiled collectors will perform poorly. Periodic cleaning may be necessary in dry, dusty climates.
- Collector glazing and seals: Look for cracks in the collector glazing, and check to see if seals are in good condition. Plastic glazing, if excessively yellowed, may need to be replaced
- Plumbing, ductwork, and wiring connections: Look for fluid leaks at pipe connections. Check duct connections and seals. Ducts should be sealed with a mastic compound. All wiring connections should be tight.
- Roof penetrations: Flashing and sealant around roof penetrations should be in good condition.
- Support structures: Check all nuts and bolts attaching the collectors to any support structures for tightness.
- Pressure relief valve (on liquid solar heating collectors): Make sure the valve is not stuck open or closed.
- Pumps: Verify that distribution pumps are operating. Listen to see if they come on when the sun is shining on the collectors after mid-morning. If you can't hear a pump operating, then either the controller has malfunctioned or the pump has.
- Heat transfer fluids: Antifreeze solutions in liquid (hydronic) solar heating collectors need to be replaced periodically. It's a task best left to a qualified technician. If water with a high mineral content (i.e., hard water) is circulated in the collectors, mineral build up in the piping may need to be removed by adding a de-scaling or mild acidic solution to the water every few years.

- Storage systems: Check storage tanks, etc., for cracks, leaks, rust, or other signs of corrosion.

## PRESSURE DROP CHART :

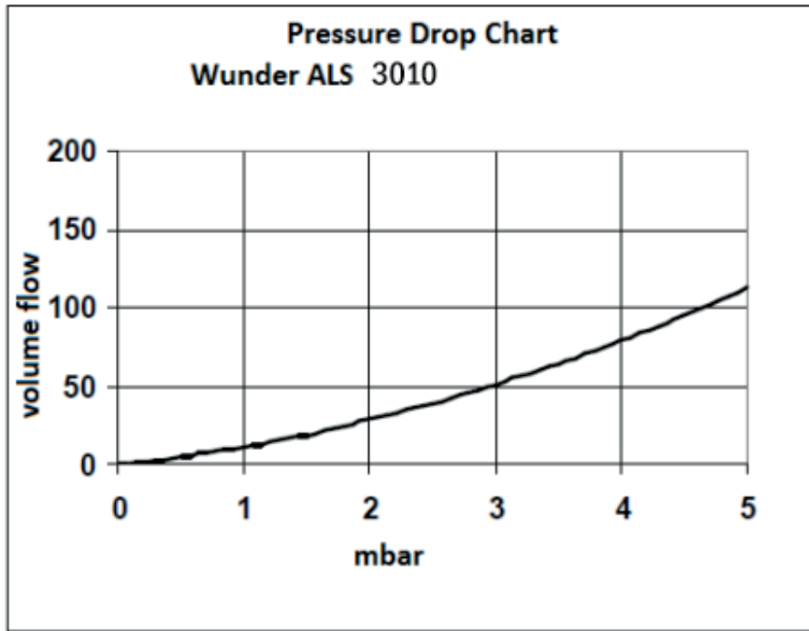

## PRECAUTIONS TO BE TAKEN DURING FILLING, OPERATION AND SERVICE :

- **WARNING!** During filling the installation, keep all precautions recommended by the manufacturer of the liquid.
- When refilling, maintenance of installation attention should be paid to the temperature of the liquid to prevent possibility of scalding.
- During operations of installation, especially during stagnation, collector elements and pipe installation are very hot. Attention should be paid to prevent possibility of scalding
- Do not place in the sun unfilled collector. If necessary, cover collector with non-transparent material, protecting it from sunlight. Installation can be filled only in the absence of solar radiation (high cloudiness) or when the collector is covered.

