

SOLIMPEKS
Renewable Heating

THERMOSIPHON SYSTEMS

TSM 120L

TSM 150L

TSM 200L

TSM 300L

**INSTALLATION, OPERATION AND MAINTENANCE MANUAL
(PERFIL ALTO & PERFIL AJÓ)**



1.	Observance of the instructions and standards	2
1.1	Relevant Standards.....	2
1.2	Applicable Requirements	2
2.	Description of Solar System and Components.....	2
2.1	General Description.....	2
2.2	Collectors.....	3
2.3	Boilers.....	3
2.4	Assembly Kit	4
2.5	System Schematic Drawing	6
2.6	TSM 120, TSM 150, TSM 200L Assembly Kit Composition	7
2.7	TSM 300 Assembly Kit Composition.....	9
2.8	Thermal Fluid.....	11
2.9	Identification	11
2.10	Packaging, Transport and Storage.....	11
2.11	Lightning Protection	11
2.12	Water Contamination.....	11
3.	Installation.....	12
3.1	General Directions.....	12
3.2	Permissible (maximum) Wind and Snow Load.....	14
3.3	Systems Dimension and Weight.....	15
3.4	Assembly Instructions for Flat Roof Mounting Kit (Perfil Bajo).....	16
3.5	Assembly Instructions for Flat Roof Mounting Kit 200 (Perfil Alto).....	19
3.6	Assembly Instructions for Flat Roof Mounting Kit 300 (Perfil Alto).....	21
3.7	Assembly Instructions for Onto Roof Mounting Kit (Perfil Alto).....	22
3.8	Assembly Instructions for Onto Roof Mounting Kit at 12° & 15° (Perfil Bajo)	24
3.9	Hydraulic Connections.....	26
3.10	Electrical Component (Optional).....	27
4.	Commissioning of the system	27
4.1	Filling the System	27
4.2	Final Control	28
5.	Trouble Shooting	28
6.	Annual Performance Calculations	29
7.	Warranty	30

1. Observance of the instructions and standards

It is very important to follow these installation, operating and maintenance instructions, in order to avoid any property damage, injury and to have your device functioning properly in the long run. The company that manufactured this solar system has no liability for the installer and/or the user in case these instructions have not been followed carefully.

Whatever further information or clarifications are needed, please contact the supplier of the product.

1.1 Relevant Standards

ISO 9806:2013: *Energy – Solar Thermal Collectors – Test methods*

EN 12975-1: *Thermal solar systems and components – Solar collectors -part 1: General requirements.*

EN 12975-2: *Thermal solar systems and components – Solar collectors – part 2: Test methods.*

EN 12976-1: *Thermal solar systems and components – Factory made systems - part 1: General requirements.*

EN 12976-2: *Thermal solar systems and components – Factory made systems – part 2: Test methods.*

1.2 Applicable Requirements

These systems are in conformity with the applicable requirements of the following documents:

Ref. No.	Title
EN 60335-1:2012 +A11:2014	Household and similar electrical appliances — Safety — Part 1: General requirement
EN 60335-2-21:2003 +A2:2008	Household and similar electrical appliances — Safety— Part 2-21: Particular requirements for storage water heaters
EN 62305-3:2021	Physical damage to structures and life hazard
EN 806-1	Specification for installations inside buildings conveying water for human consumption – Part 1: General
EN 806-2	Specification for installations inside buildings conveying water for human consumption - Part 2: Design

2. Description of Solar System and Components

2.1 General Description

This solar system is a closed loop thermosiphon unit which produces hot water for domestic use. The system contains all the necessary equipment to function properly. These are mainly:

- *Collector(s)*
- *Solar tank*
- *Support structure*
- *Assembly kit*

Solimpeks thermosiphon systems are available in the following models:

- **TSM 120**
- **TSM 150**
- **TSM 200**
- **TSM 300**

2.2 Collectors

The collectors are manufactured in 3 sizes. The absorbers of the collectors are made by copper tubes and the fins area by selective aluminum fins. The fins are welded to the tubes by laser welding. The frame of the collector is made by extruded aluminum electrostatic painted to resist ambient conditions and corrosion.

The glass cover is a low iron tempered glass of 4mm thickness for maximum penetration of solar irradiation. At the back and sides of the absorber there is sufficient insulation of rock wool/glass wool to minimize heat loses and to resist stagnation temperatures.

Technical Data of Collectors

Specification / Type	Wunder ALS 1809	Wunder ALS 2110	Wunder ALS 2512	Wunder ALS 2110 (2 pcs)
Dimensions	1927 x 927 x 90 mm	1988 x 1041 x 90 mm	1988 x 1218 x 90 mm	1988 x 1041 x 90 mm
Casing Material	Electrostatic Painted Aluminum Case	Electrostatic Painted Aluminum Case	Electrostatic Painted Aluminum Case	Electrostatic Painted Aluminum Case
Weight	34 kg	37,2 kg	44 kg	37,2 kg
Sealing Material	EPDM & Silicone & ALUMINUM FRAME	EPDM & Silicone & ALUMINUM FRAME	EPDM & Silicone & ALUMINUM FRAME	EPDM & Silicone & ALUMINUM FRAME
Gross Area	1.79 m ²	2.07 m ²	2.42 m ²	2.07 m ²
Aperture Area	1.62 m ²	1.92 m ²	2.24 m ²	1.92 m ²
Absorber Area	1.62 m ²	1.90 m ²	2.23 m ²	1.90 m ²
Absorber Material	Alu-Selective Coated	Alu-Selective Coated	Alu-Selective Coated	Alu-Selective Coated
Absorptance	95%	95%	95%	95%
Emittance	3%	3%	3%	3%
Welding Method	Laser welding	Laser welding	Laser welding	Laser welding
Diameter of Absorber Tube	8 mm	8 mm	8 mm	8 mm
Diameter of Header Tube	18 mm	18 mm	18 mm	18 mm
Number of Tubes	9	10	12	9
Glass Material	Low Iron Tempered Glass	Low Iron Tempered Glass	Low Iron Tempered Glass	Low Iron Tempered Glass
Transmittance of Glass	91%	91%	91%	91%
Thickness of Glass	4 mm	4 mm	4 mm	4 mm
Insulation Material	High Density Rock wool	High Density Rock wool	High Density Rock wool	High Density Rock wool
Density of wool	50 Kg/m ³	50 Kg/m ³	50 Kg/m ³	50 Kg/m ³
1000 W/m and 30 °C	203 °C	203 °C	203 °C	203 °C
Max. Operation Pressure	10 bar	10 bar	10 bar	10 bar
Test Pressure	20 bar	20 bar	20 bar	20 bar
Pressure Loss	1.6 bar	1.6 bar	1.8 bar	1.6 bar
Back Sheet	Embossed - finished Aluminum	Embossed - finished Aluminum	Embossed - finished Aluminum	Embossed - finished Aluminum
Mounting Mode	onto-roof, flat roof	onto-roof, flat roof	onto-roof, flat roof	onto-roof, flat roof

2.3 Boilers

The solar accumulation tank is an indirect (double circuit) hot water horizontal cylinder. It is protected against rusting with a large magnesium anode.

The ecologic polyurethane foam insulation guaranties minimum thermal loses even at very low ambient temperatures. The external cover of the tank can resist any extreme weather conditions for life. The internal heat exchanger with large surface guaranties the energy transfer to the domestic hot water.





The safety valve only opens to discharge when the system pressure exceeds 6 bar in the form of water.







Technical Data of Boilers





Specification	TSM 120L	TSM 150L	TSM 200L	TSM 300L
Boiler	S235JR-Sheet, CR Ni stainless steel flexible heat exchanger	S235JR-Sheet, CR Ni stainless steel flexible heat exchanger	S235JR, CR Ni stainless steel flexible heat exchanger	S235JR, CR Ni stainless steel flexible heat exchanger
Capacity	120 l/day	150 l/day	200 l/day	300 l/day
Overlay	Electro static painted steel	Electro static painted steel	Electro static painted steel	Electro static painted steel
Insulation	PU / 50 mm, 42 density	PU / 50 mm, 42 density	PU / 50 mm, 42 density	PU / 50 mm, 42 density
Extra Heater – optional	2000 W. Heater	2000 W. Heater	2000 W. Heater	3000 W. Heater
Net Weight	60 kg	72 kg.	90 kg.	108 kg.
Full Weight	160 kg.	195 kg.	240 kg.	332 kg.
Working Pressure	0-6 bar	0-6 bar	0-6 bar	0-6 bar

2.4 Assembly Kit

The material list for each set of assembly kit is:

CODE	DESCRIPTION	PICTURE	QUANTITIES FOR FLAT ROOF			QUANTITIES FOR ONTO ROOF				
			TSM200 45-50°	TSM200 35-40°	TSM300	TSM200	TSM200 15°	TSM200 12°	TSM300 12/15°	TSM300
HA-0346	Plug ¾", Male		2	2	2	2	2	2	2	2
HA-0345	Plug X ¾", Female		2	2	2	2	2	2	2	2
HA-0393	Cable Tie, 450 X 4,8mm		1	1	1	1	1	1	1	1
TI-0293	Safety valve ½", 3 bars		1	1	1	1	1	1	1	1

TI-0302	Reducing nipple, 3/4" Male / 1/2" Male		1	1	1	1	1	1	1	1
TI-0292	Nipple 3/4"		3	3	3	3	3	3	3	3
TI-0306	Connection, T, 3/4"		1	1	1	1	1	1	1	1
YA-0694	Flexible connection, 2970mm		-	-	-	-	-	-	-	1
	Flexible connection, 2170mm		-	-	-	1	-	-	-	-
	Flexible connection, 440mm		1	-	-	-	1	-	-	-
	Flexible connection, 550mm		-	-	1	-	-	-	1	-
	Flexible connection, 2010mm		1	-	-	-	1	-	-	-
	Flexible connection, 370mm		-	1	-	-	-	1	-	-
	Flexible connection, 2120mm		-	-	1	-	-	-	1	-
	Flexible connection, 2030mm		-	1	-	-	-	1	-	-
	Flexible connection, 610mm		-	-	-	1	-	-	-	-
	Flexible connection, 2310mm		-	-	-	-	-	-	-	-
OPTIONAL ITEMS										
CODE	DESCRIPTION	PICTURE	QUANTITIES FOR FLAT ROOF			QUANTITIES FOR ONTO ROOF				
			TSM200 45-50°	TSM200 35-40°	TSM300	TSM200	TSM200 15°	TSM200 12°	TSM300 12/15°	TSM300
TI-0314	Expansion Tank, 8L		1	1	-	1	1	1	-	-
TI-0065	Expansion Tank, 12L		-	-	1	-	-	-	1	1
TI-0299	Automatic Air Vent 1/2"		1	1	1	1	1	1	1	1

TI-0079	Thermostat		1	1	1	1	1	1	1	1
TI-0080	Heater		1	1	1	1	1	1	1	1
TMA-012	Pressure reducer valve		1	1	1	1	1	1	1	1
HA-0255	Ring		6	6	8	6	6	6	8	8

2.5 System Schematic Drawing

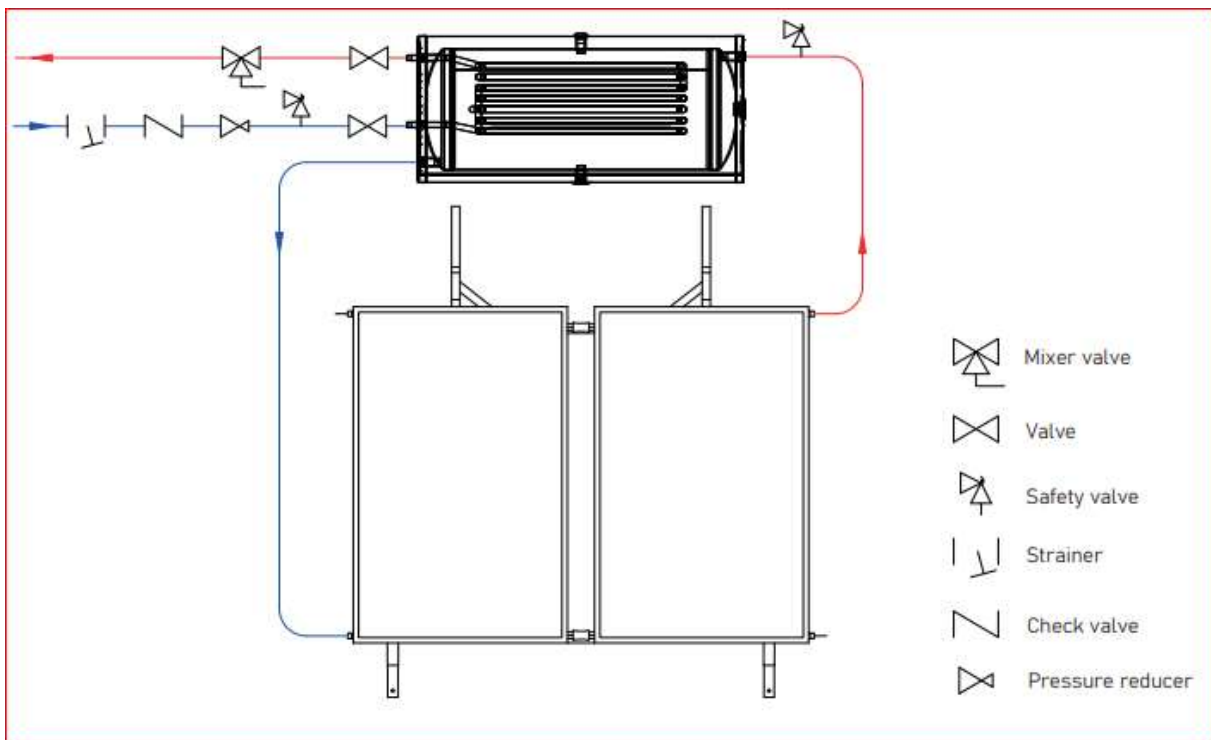

In TSM systems, there is no pressure in the tank in the first installation. Depending on the radiation, the temperature and pressure of the water in the tank increase. The safety valve in the collector return line discharges the water and balances the tank pressure if the system pressure exceeds 6 bar.

2.6 TSM 120, TSM 150, TSM 200L Assembly Kit Composition

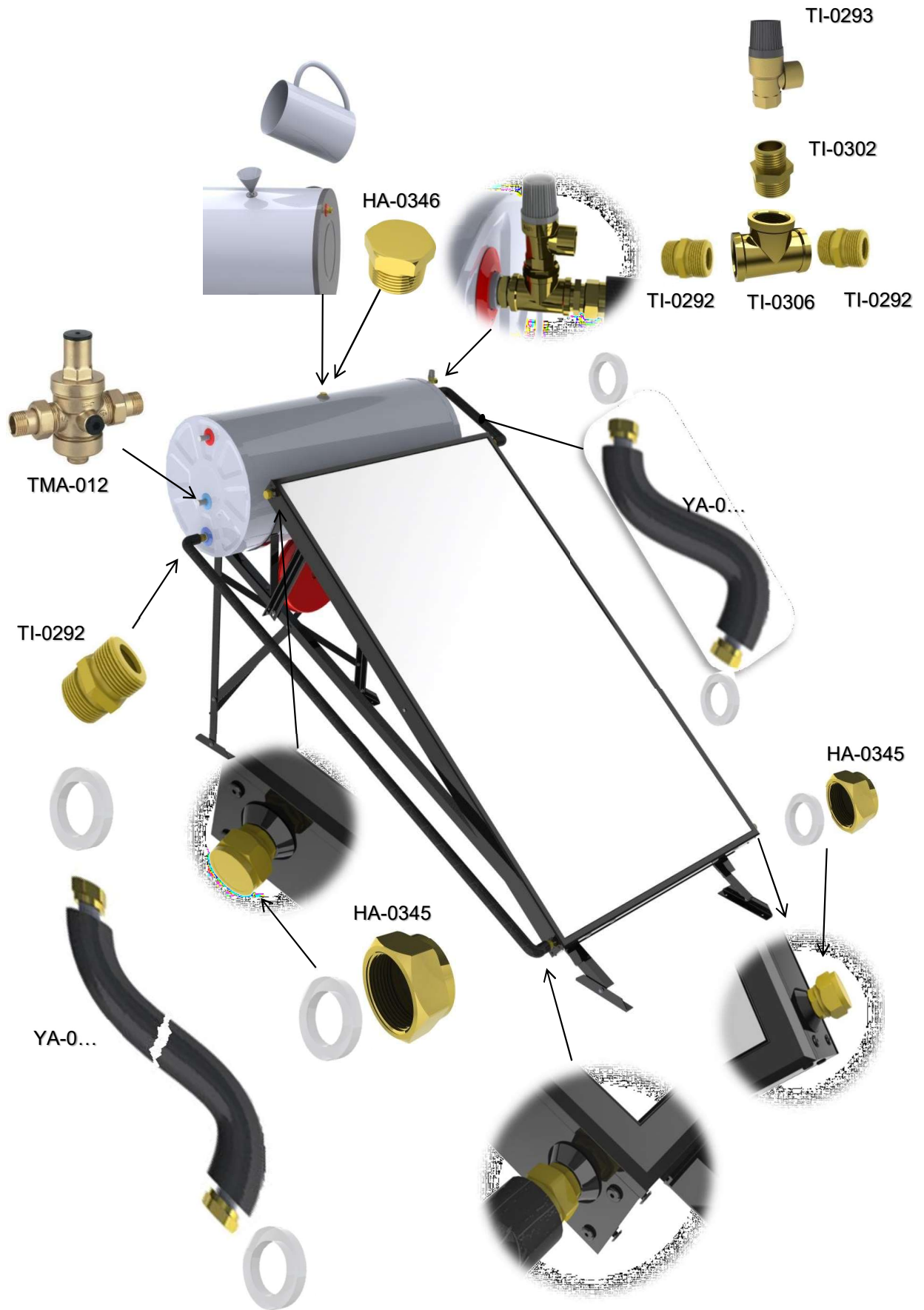

PART	CODE	DESCRIPTION
1	HA-0346	Plug 3/4", Male
2	TI-0292	Nipple, 3/4"
3	TI-0373	Valve, Safety, 4 bar, 1/2", the MSV / E (0207540)
4	TI-0306	Connection, T, 3/4" x 1/2" x 3/4"
5	HA-0345	End Cap 3/4" Female
6	YFX-0..	Flexible connection,
7	YFX-0..	Flexible connection,

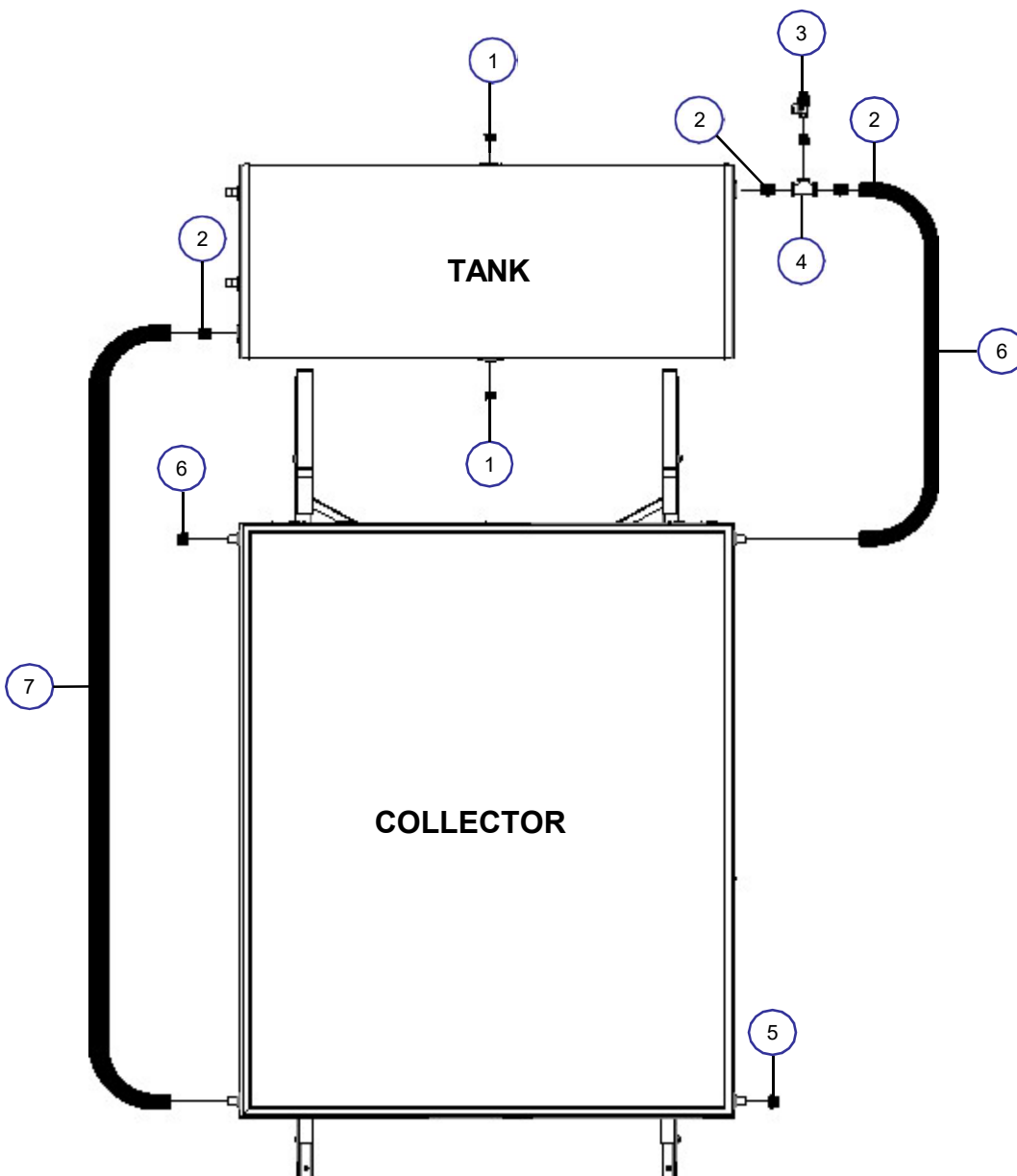

2.7 TSM 300 Assembly Kit Composition

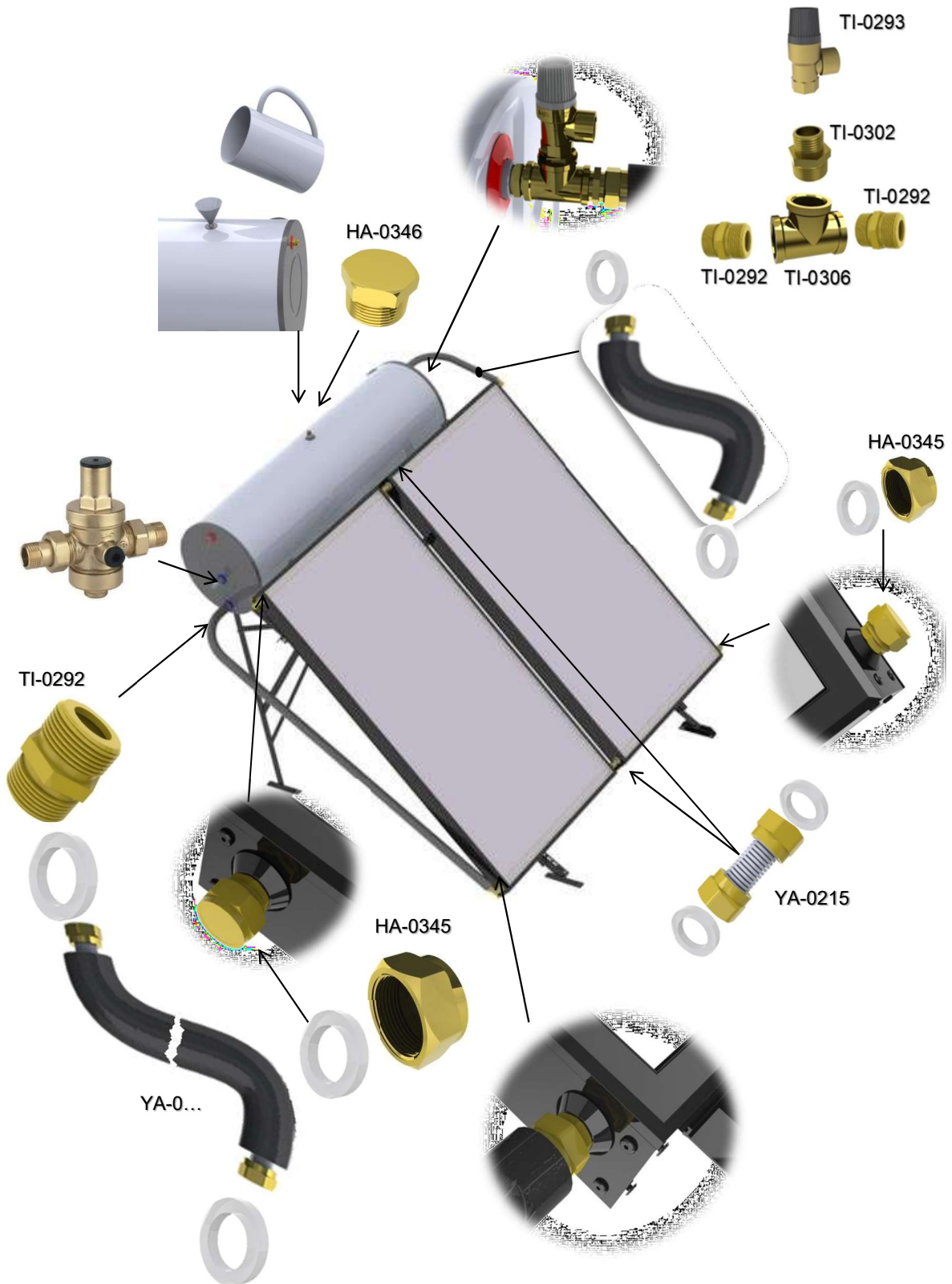

PART	CODE	DESCRIPTION
1	HA-0346	Plug 3/4", Male
2	TI-0292	Nipple, 3/4"
3	TI-0373	Valve, Safety, 4 bar, 1/2", the MSV / E (0207540)
4	TI-0302	Reducing nipple, 3/4" Male / 1/2" Male
5	TI-0306	Connection, T, 3/4"
6	HA-0345	End Cap 3/4" Female
7	YFX-0..	Flexible connection,
8	YFX-0..	Flexible connection,
9	YFX-0..	Flexible connection,

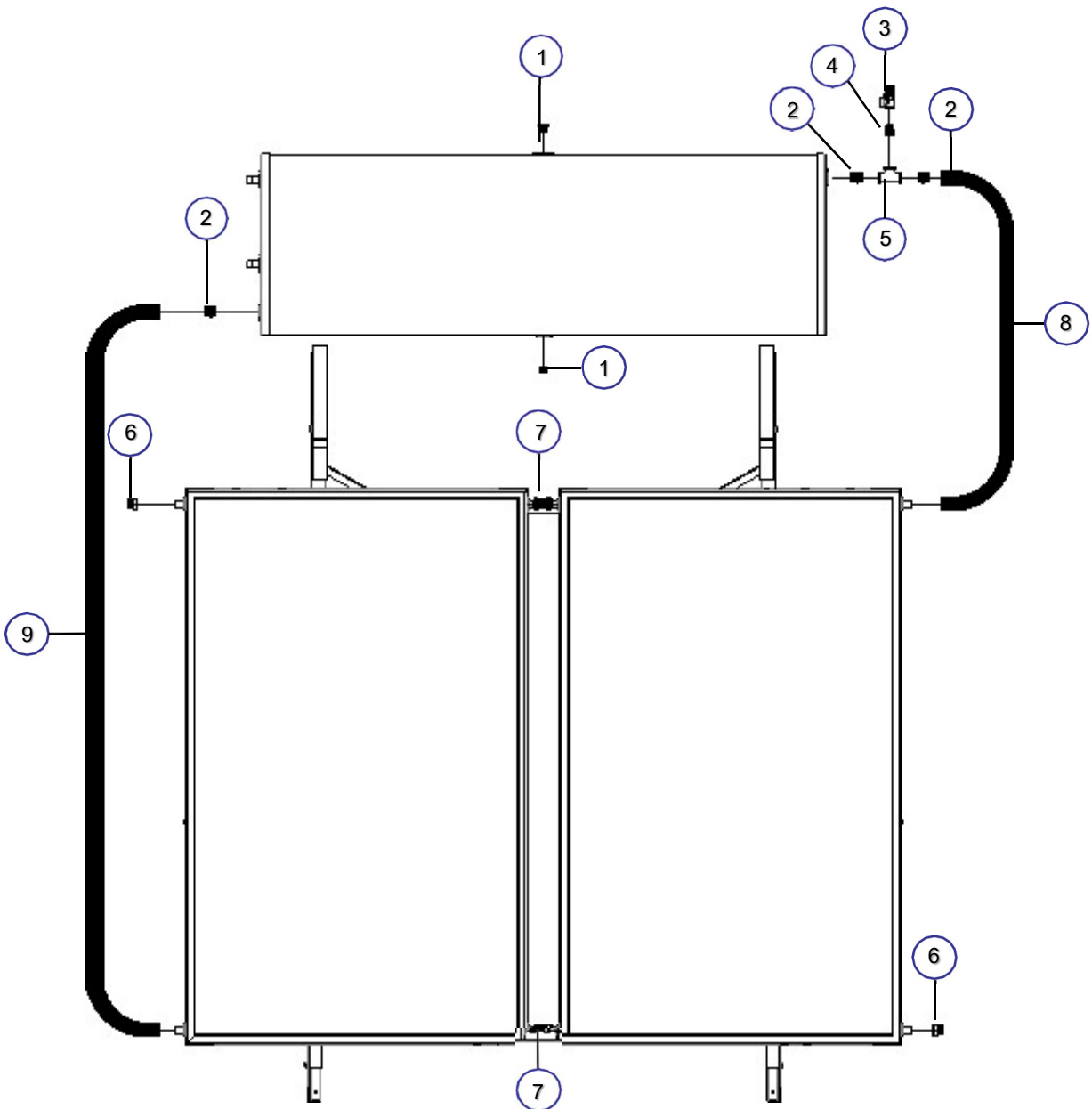

2.8 Thermal Fluid

The thermal energy collected from the solar irradiation by the collector is transferred to the heat-exchanger of the tank by the thermal fluid, which is naturally re circulated by the thermosiphonic principle in the closed loop system. The heat exchanger is heating the domestic consumption water. The solution contains inhibitors for corrosion protection. The solution also inherit antifreeze for antifreeze protection up to -37°C.

2.9 Identification

Solimpeks thermosiphon systems are identified by the stickers on the sides of the collector. On these stickers all the details of the system are written. The information provided on the stickers are important for the future identification of the system.



Removing the stickers will make the future identification difficult and will cause problems for the service and warranty procedure.

2.10 Packaging, Transport and Storage

Solimpeks's thermosiphon system is well packaged in a way that the components will be delivered in good condition. The collector model is indicated on the outside of each box and the tank model is indicated outside of each package. The packaging of the components should be removed at the place which will be installed. Depending on the number of units ordered, collectors can be supplied palletized in groups of up to 11 units.

It is recommended to use special safety belts during transportation in order to avoid movements and/or falling. Before removing the packaging make a final inspection of the system and count the components that were delivered. Make sure that they are according to the assembly kit composition table.



The installer should follow all the safety rules.



Do not stand on the packed components.

2.11 Lightning Protection

Solimpeks declares that lightning protection complies with EN-62305-3.

2.12 Water Contamination

To prevent water contamination, a safety valve should be installed on the domestic cold water inlet.

Legionella bacteria reproduce very quickly in still water between 20°C and 50°C. Since the domestic water is instantly heated in the spiral structure Chrome-Nickel 316L stainless steel in the TSM Warehouse, there is no Legionella bacteria formation in this type of boiler.

3. Installation

3.1 General Directions

The assembly of the thermosiphon system must be done by a specialized technician. All the components of the solar system are included in the packaging.

Before the assembly of the thermosiphon system check:

- a. The condition of all the components,
- b. The exact position of the system and the right orientation.

In windy or snowy places, extra care must be taken for these conditions. For further advice contact the company.

The choice of location, inclination and orientation of the solar system has to be determined at the design stage of the installation. The installation of the solar system in the building should be carried out respecting the instruction of the person in charge of the project, who should have taken into consideration the effect of the orientation, inclination and possible shadows in the calculation of benefits of the solar system.

Particular attention should be paid to the minimum distance maintained between a wall and an obstacle in front of a system.

The distance should not be less than indicated below.

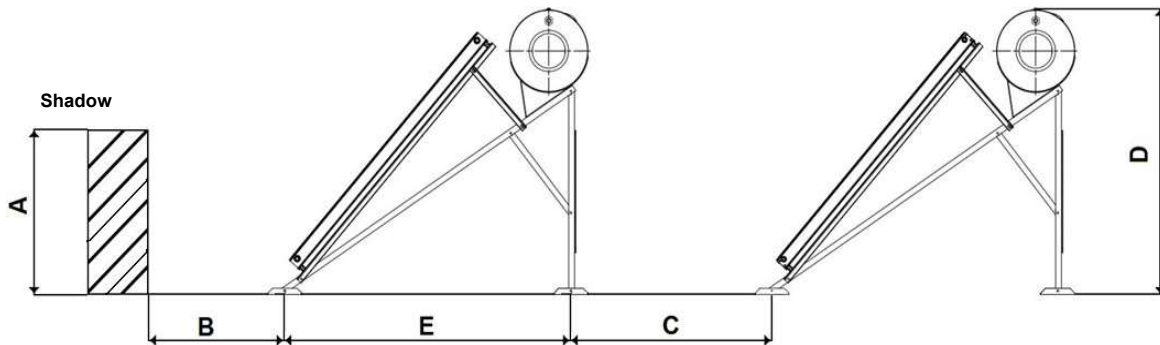

MODEL	LENGTH									
	B	C	D				E			
			35°	40°	45°	50°	35°	40°	45°	50°
TSM 200 & TSM 300	A x 1,85	D x 1,50	1475mm	1625mm	1739mm	1878mm	2200mm	2130mm	2055mm	1975mm

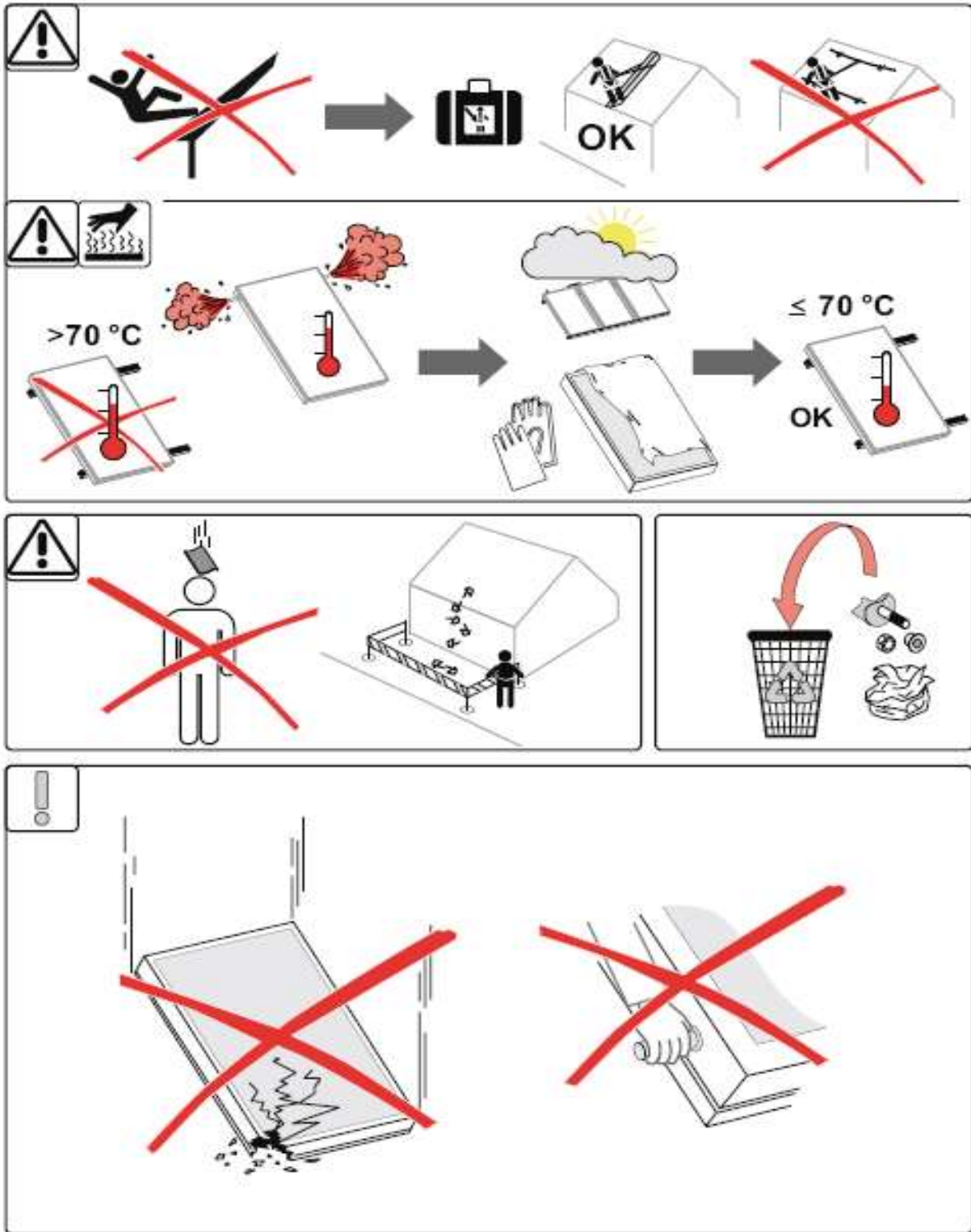

Slope and direction of the collector on the roof

To get the best efficiency from the solar collector, it must be mounted at the right direction and slope. Both the slope angle and azimuth angle must be calculated before and while mounting the collector on the roof.

Slope angle α

Slope angle α is the angle between the collector and horizontal (x) axis. The absorber used in the collector can get the most efficient energy when it is mounted absolutely vertically to the Sun's rays. The angle of the Sun's rays varies subject to hourly and seasonal changes. Hence the collectors must be aligned with the correct angle and slope. It is advised that the angles between 30 and 45 degrees are the most ideal angles to mount the collector.

Minimum and Maximum Tilt Angle of the Collectors

The collectors can be set as min. 15° and max. 60 ° angles on the flat roof installations.

Azimuth angle

Azimuth angle means the deflection of the collector axis from south direction. So the angle of the collectors direction to the south is zero (0). The axis of the collector should be positioned as close as possible to the south. This is because the Sun's rays are at their peak at noon. The deviation up to 45 degrees to the south can be accepted.

3.2 Permissible (maximum) Wind and Snow Load

The maximum snow load (sk) and main wind speed (vm) values the solar collector-support unit can withstand with the sloping roof supports are sk = 0.66 and vm = 1.75, and so the system may only be installed in areas with values lower than these. With combined snow and wind loads the maximum strain for Wunder collectors is 2000 N/m².

3.3 Systems Dimension and Weight

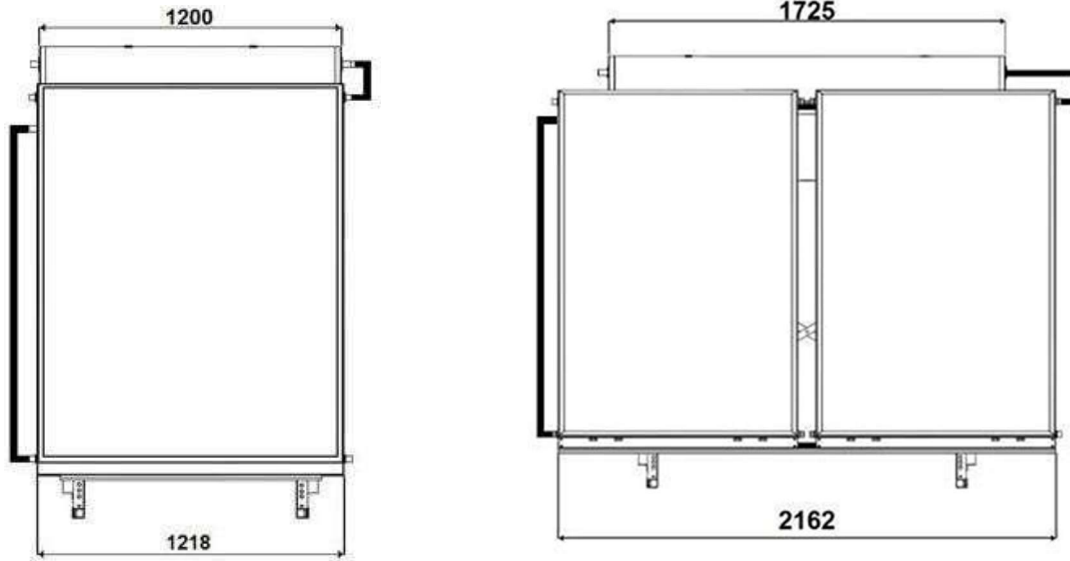

FLAT ROOF							
BOILER			COLLECTOR				MOUNTING KIT
Model	Dimensions (mm)	Empty Weight (kg)	Model	Dimensions (mm)	Unit	Weight (kg)	Weight (kg)
TSM 120	Ø 540 x 951	60	ALS1809	1927 X 927 X 90	1	33	32 to 35 kg
TSM 150	Ø 540 x 1066	72	ALS2110	1988 X 1041 X 90	1	38	32 to 35 kg
TSM 200	Ø 540 x 1200	90	ALS2512	1988 X 1218 X 90	1	44	32 to 35 kg
TSM 300	Ø 540 x 1725	108	ALS2110	1988 X 1041 X 90	2	76	32 to 35 kg

ONTO ROOF							
BOILER			COLLECTOR				MOUNTING KIT
Model	Dimensions (mm)	Empty Weight (kg)	Model	Dimensions (mm)	Unit	Weight (kg)	Weight (kg)
TSM 120	Ø 540 x 951	60	ALS1809	1927 X 927 X 90	1	33	10 to 15 kg
TSM 150	Ø 540 x 1066	72	ALS2110	1988 X 1041 X 90	1	38	10 to 15 kg
TSM 200	Ø 540 x 1200	90	ALS2512	1988 X 1218 X 90	1	44	10 to 15 kg
TSM 300	Ø 540 x 1725	108	ALS2110	1988 X 1041 X 90	2	76	10 to 15 kg

3.4 Assembly Instructions for Flat Roof Mounting Kit (Perfil Bajo)



Image – 1: 2R - Right Collector Frame



Image – 2: 2L - Left Collector Frame



Image – 4: 1L - Left Roof Frame

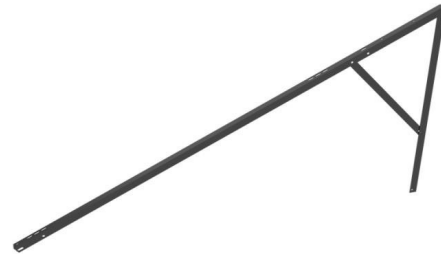

Image – 3: 1R - Right Roof Frame



Image – 5: Tank Holder Frame

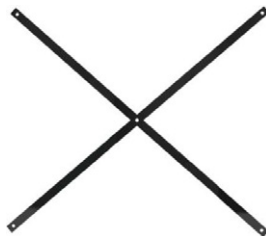

Image – 6: 3R-Diagonal Part for Roof Frames Connection

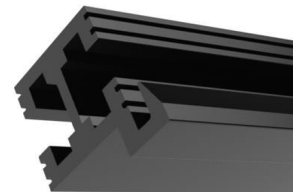

Image – 7: Aluminum Profile



Image – 8: Nut



Image – 9: Bolt



Image – 10: Mounting Shoe

Assembly Steps

- 1- Open the pack of the support system. Identify the items from the images.
- 2- Assembly 1L and 1R with mounting shoes.
- 3- Assembly 1L with 3R and 1R with 3R between themselves using the bolts and nuts included in the pack. Fasten tight the bolts.

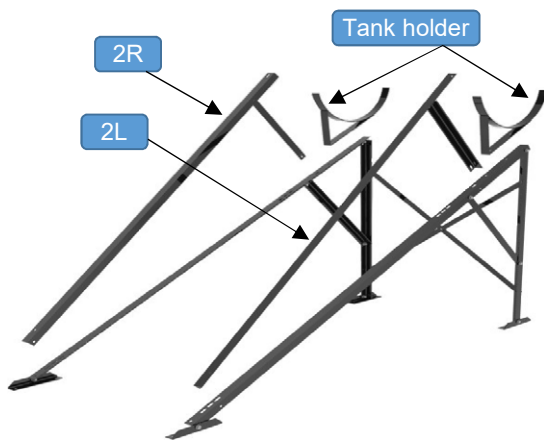
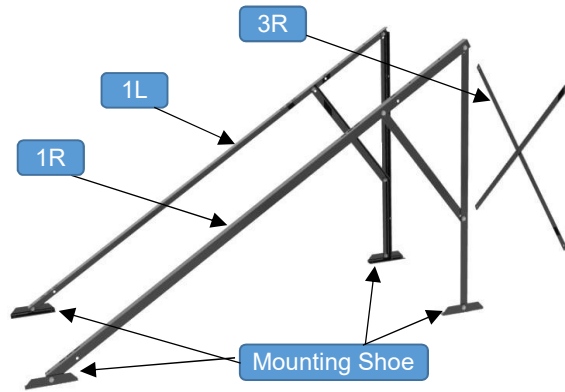

- 4- Assembly 2L and 1L between themselves using the bolts and nuts included in the pack.
- 5- Assembly 2R and 1R between themselves using the bolts and nuts included in the pack.
- 6- Check the alignment of the collector frames with a meter (2L and 2R).
- 7- Assembly one of the tank holder to the 1L frame, one of the tank holder to the 1R frame. Your support frame should look like image – 11.

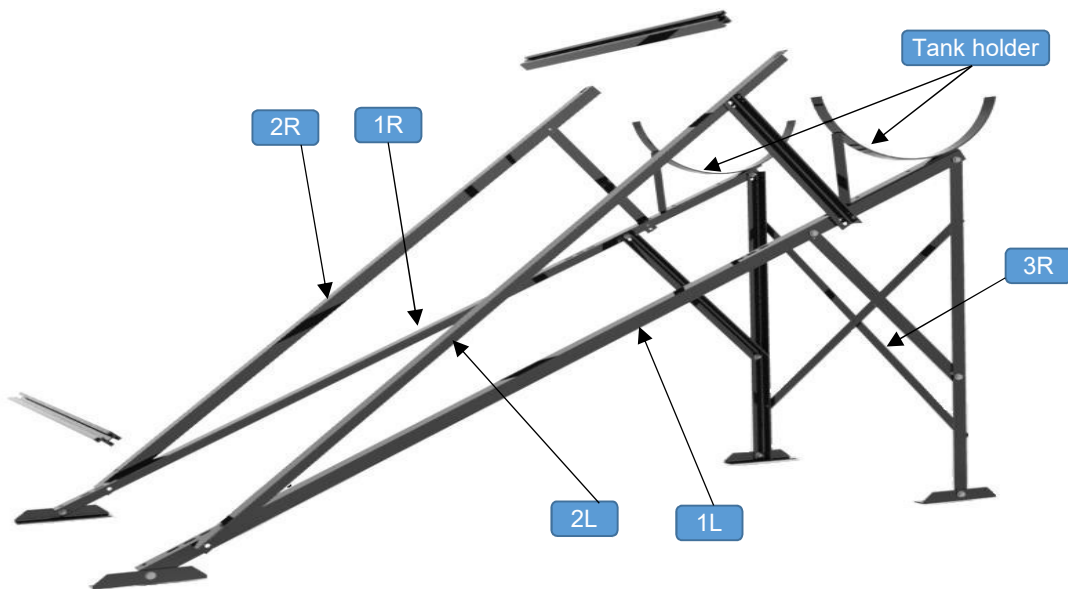

Image – 11: Flat roof support frame sub-assembly

- 8- Assembly one of the aluminum profile to the lower part of the sub-assembly frame with bolts and nuts as shown in the image – 12. Bolt head slides in aluminum profile. At this stage do not fasten tight the bolts.
- 9- Assembly other aluminum profile to the lower part of the sub-assembly frame with bolts and nuts as shown in the image – 12. Bolt head slides in aluminum profile. At this stage do not fasten tight the bolts.
- 10- Align the aluminum profile horizontally with a meter. The protruding length at the start and at the end of aluminum profile should be equal.

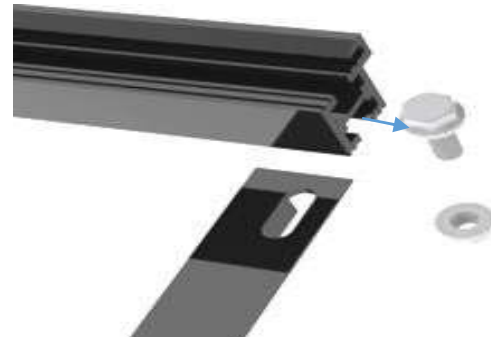
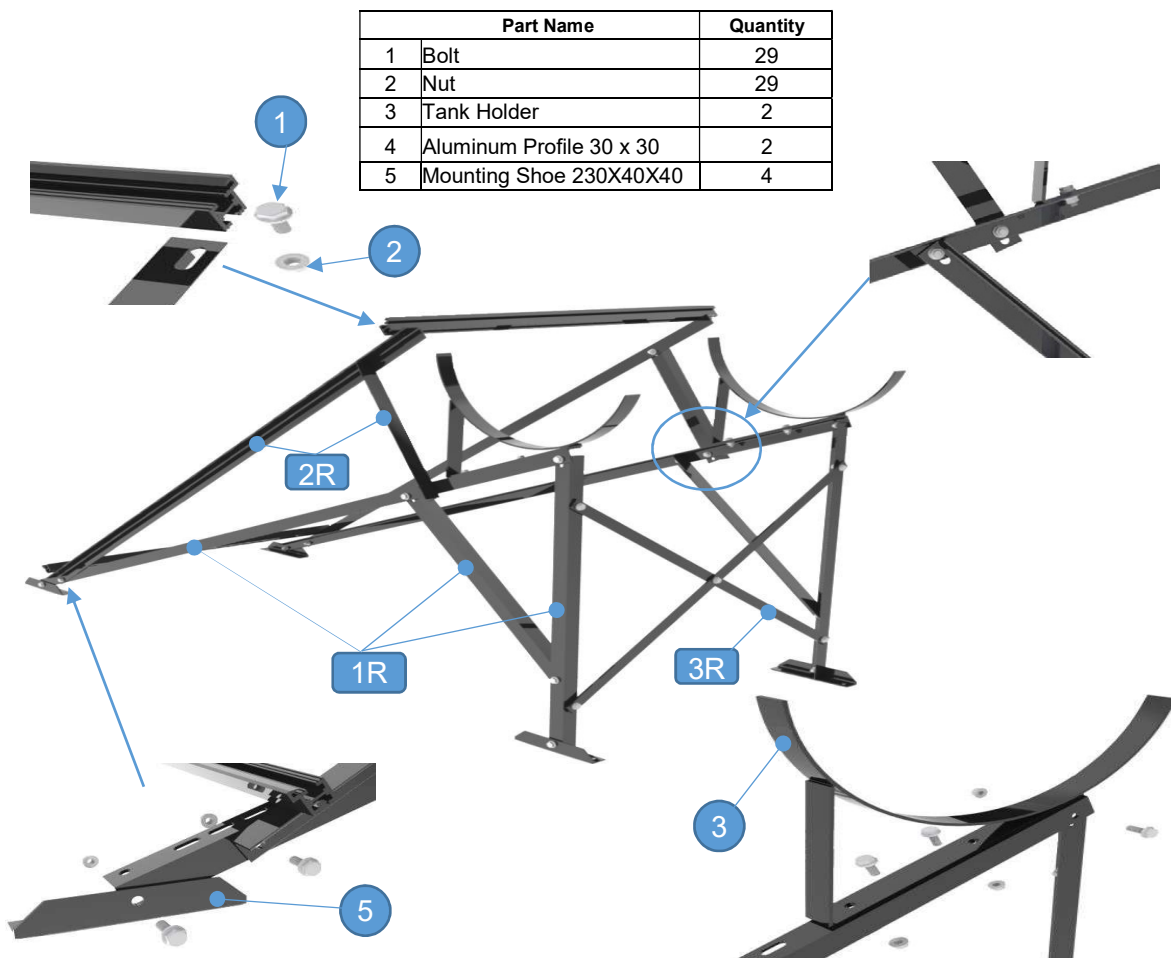
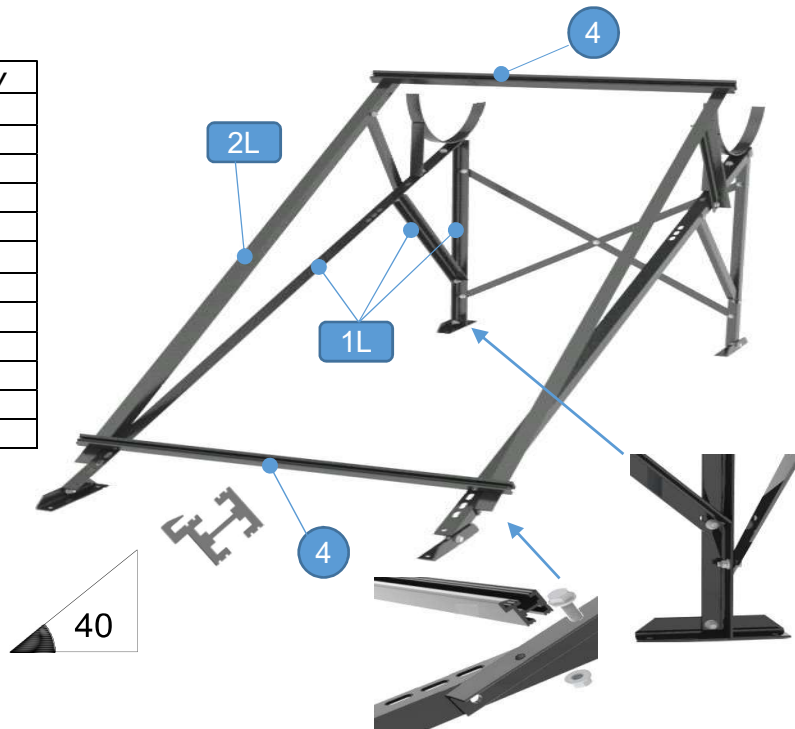

Image – 12: Aluminum profile connection



2 bolted pieces		Quantity
3R	30X5 mm	1
1 R	2060X40X40 mm	1
	460X40X40 mm	1
1 L	2060X40X40 mm	1
	460X40X40 mm	1
3 bolted pieces		
2 R	2415X40X40 mm	1
	1080X40X40 mm	1
	700X40X40 mm	1
2 L	2415X40X40 mm	1
	1080X40X40 mm	1
	700X40X40 mm	1



Finally fix the support frame on to the roof with screws.

3.5 Assembly Instructions for Flat Roof Mounting Kit 200 (Perfil Alto)



Assembly Steps

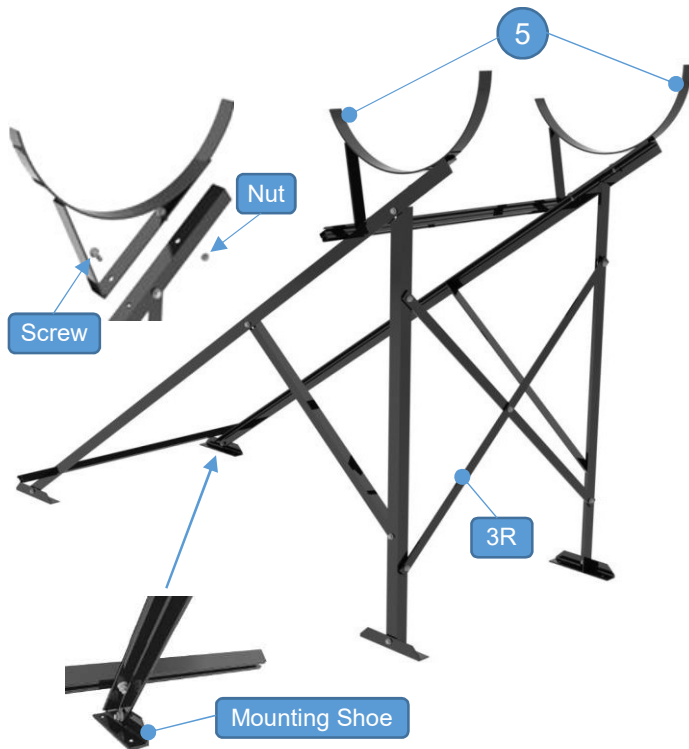

1 Collector		
No	Qty	Dimensions
1L	1	2470 X 40 X 40 mm
	1	1310 X 40 X 40 mm
	1	825 X 30 X 30 mm
1R	1	2470 X 40 X 40 mm
	1	1310 X 40 X 40 mm
	1	825 X 30 X 30 mm
3R	1	30 X 5 mm
4	2	See Aluminum profile dimensions table
5	2	Tank holder
Bolt	23	M8 X 20
Nut	23	M8
Mounting Shoe	4	230 X 40 X 40 mm

Model	Aluminum profile dimensions
2510	1041 x 30 x 30 mm
2108	1041 x 30 x 30 mm
1808	927 x 30 x 30 mm

- 1- Open the pack of the support system. Identify the items from the images.
- 2- Assembly 1L and 1R with mounting shoes.
- 3- Assembly 1L with 3R and 1R with 3R between themselves using the bolts and nuts included in the pack. Fasten tight the bolts.
- 4- Assembly one of the tank holder to the 1L frame, one of the tank holder to the 1R frame.
- 5- Assembly one of the aluminum profile to the lower part of the sub-assembly frame with bolts and nuts.
- 6- Bolt head slides in aluminum profile. At this stage do not fasten tight the bolts.
- 7- Align the aluminum profile horizontally with a meter. The protruding length at the start and at the end of aluminum profile should be equal.



8- Fix the support frame on to roof with screws.

3.6 Assembly Instructions for Flat Roof Mounting Kit 300 (Perfil Alto)



Assembly Steps

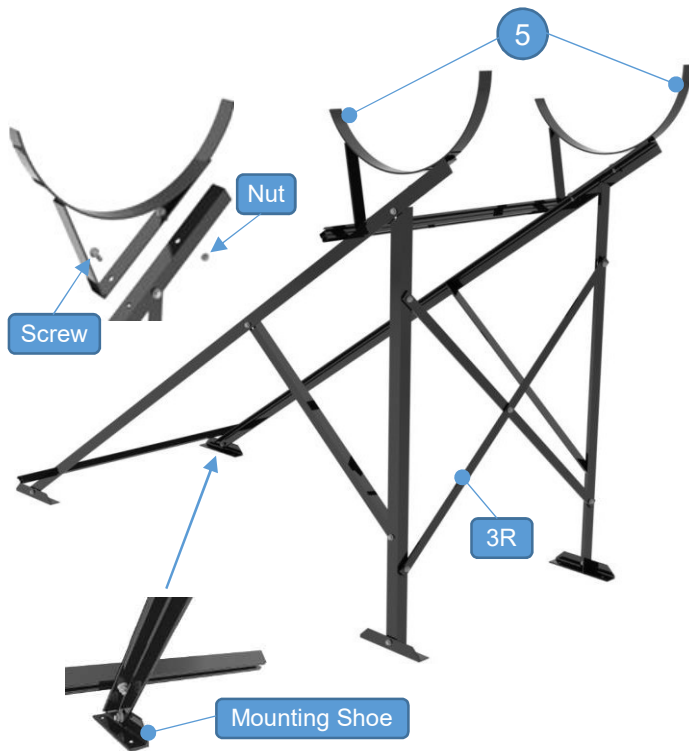

2 Collector			
No	For 1 Unit	Total Qty	Dimensions
1L	1	2	2470 X 40 X 40 mm
	1	2	1310 X 40 X 40 mm
	1	2	825 X 30 X 30 mm
1R	1	2	2470 X 40 X 40 mm
	1	2	1310 X 40 X 40 mm
	1	2	825 X 30 X 30 mm
3R	1	2	30 X 5 mm
4	2	4	See Aluminum profile dimensions table
5	2	4	Tank holder
Bolt	23	46	M8 X 20
Nut	23	46	M8
Mounting Shoe	4	8	230 X 40 X 40 mm

Model	Aluminum profile dimensions
1808	1940 x 30 x 30 mm
2108	1940 x 30 x 30 mm

- 1- Open the pack of the support system. Identify the items from the images.
- 2- Assembly 1L and 1R with mounting shoes.
- 3- Assembly 1L with 3R and 1R with 3R between themselves using the bolts and nuts included in the pack. Fasten tight the bolts.
- 4- Assembly one of the tank holder to the 1L frame, one of the tank holder to the 1R frame.
- 5- Assembly one of the aluminum profile to the lower part of the sub-assembly frame with bolts and nuts.
- 6- Bolt head slides in aluminum profile. At this stage do not fasten tight the bolts.
- 7- Align the aluminum profile horizontally with a meter. The protruding length at the start and at the end of aluminum profile should be equal.



- 8- Assembly second mounting frame like the first one.

3.7 Assembly Instructions for Onto Roof Mounting Kit (Perfil Alto)

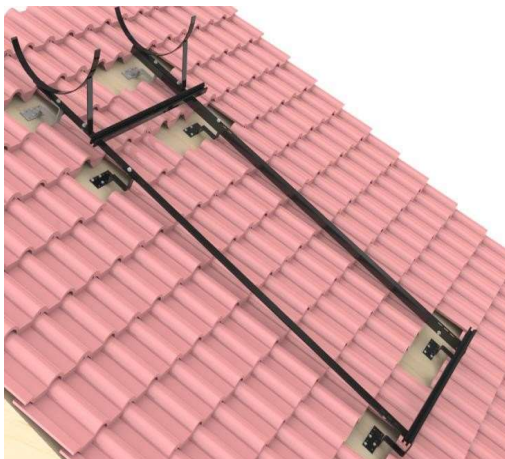

Part		Quantity
1	Support - Stainless Steel	2
2	Support - Black Painted	4
3	8 x 60 Wood Screw	18
4	Bolt	6
5	Bolt	4
6	Nut	10
7	Tank Holder	2
1 L	2415X40X40 mm	1
1 R	2415X40X40 mm	1
8	Aluminum Profile	2

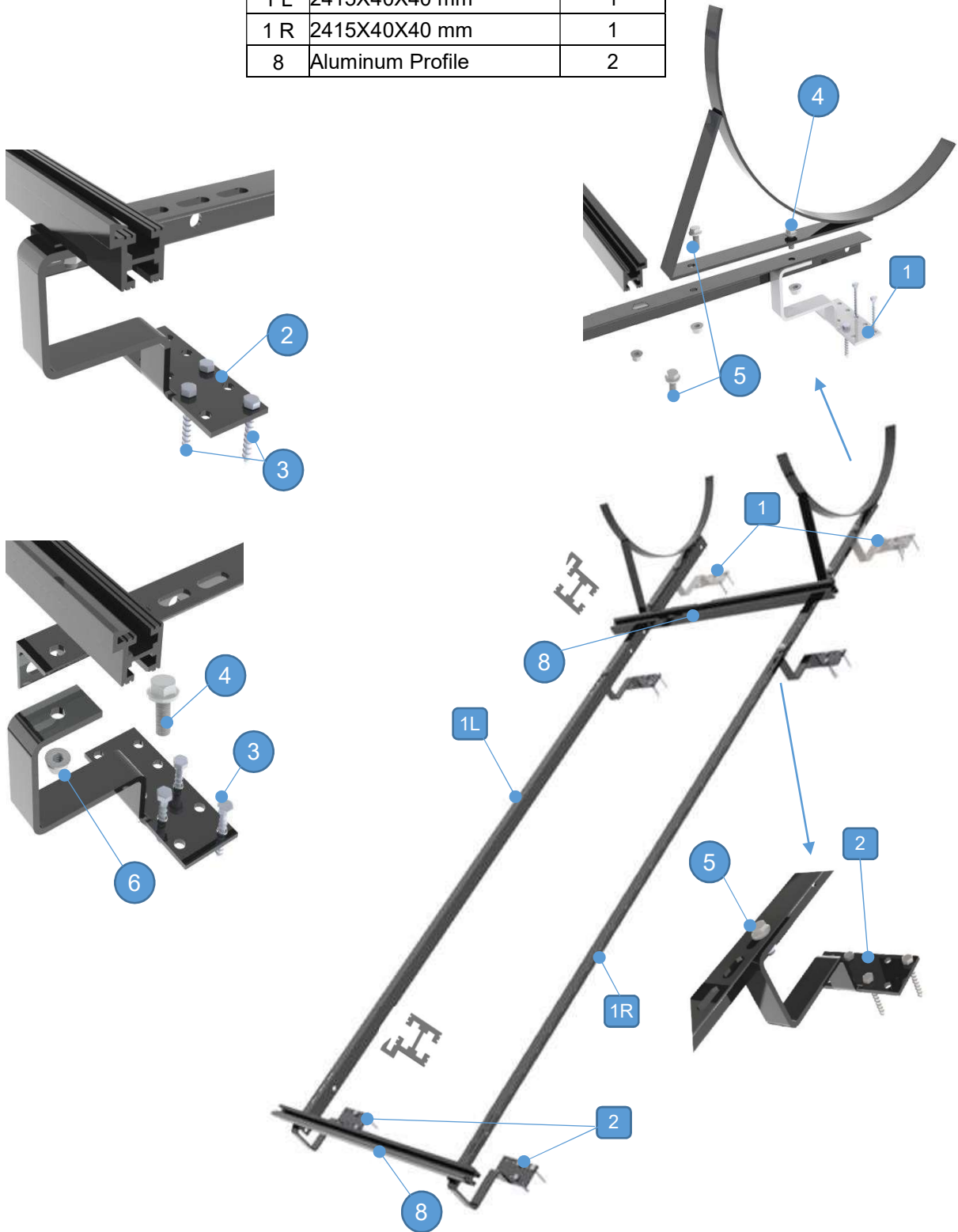

Assembly Instruction

- 1- From the inside of the roof, in the attic crawl space, measure the center-to-center distance between the roof trusses. This distance is required to secure the mount clips to the collector prior to attaching the collector to the roof structure.
- 2- Put the 1L and 1R on the supports.
- 3- Put one of the aluminum profile (8) to the lower side of the 1L and 1R horizontally.
- 4- Assembly bolts and nuts with together supports 1L / 1R and aluminum profile. At this point do not tighten bolts.
- 5- Put the other aluminum profile upper side of the 1L & 1R horizontally. The location of upper aluminum could change according to collector. Please check the dimension of the collector.
- 6- Assembly tank holder and stainless supports together with bolts and nuts to the 1L & 1R.
- 7- Measure all the dimension and adjust aluminum profiles if needed.
- 8- Tighten all bolts and check robustness of the mounting kit.

3.8 Assembly Instructions for Onto Roof Mounting Kit at 12° & 15° (Perfil Bajo)

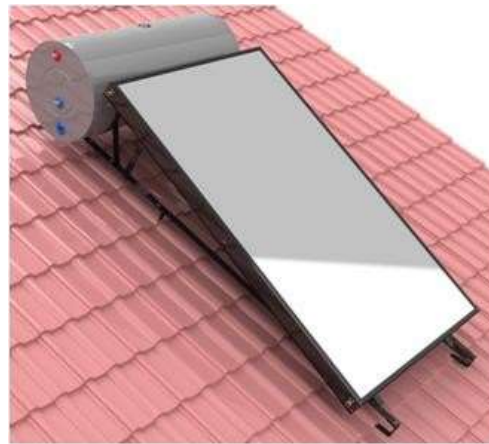
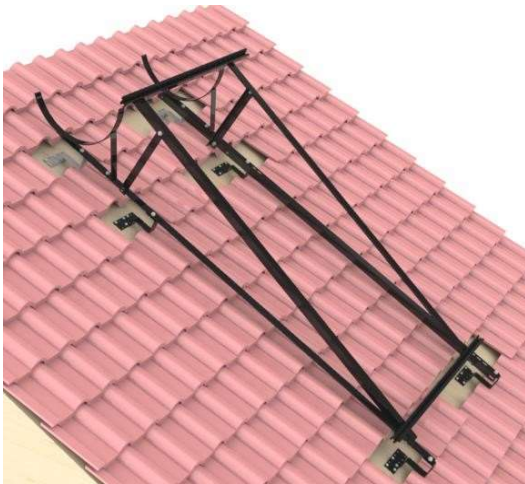

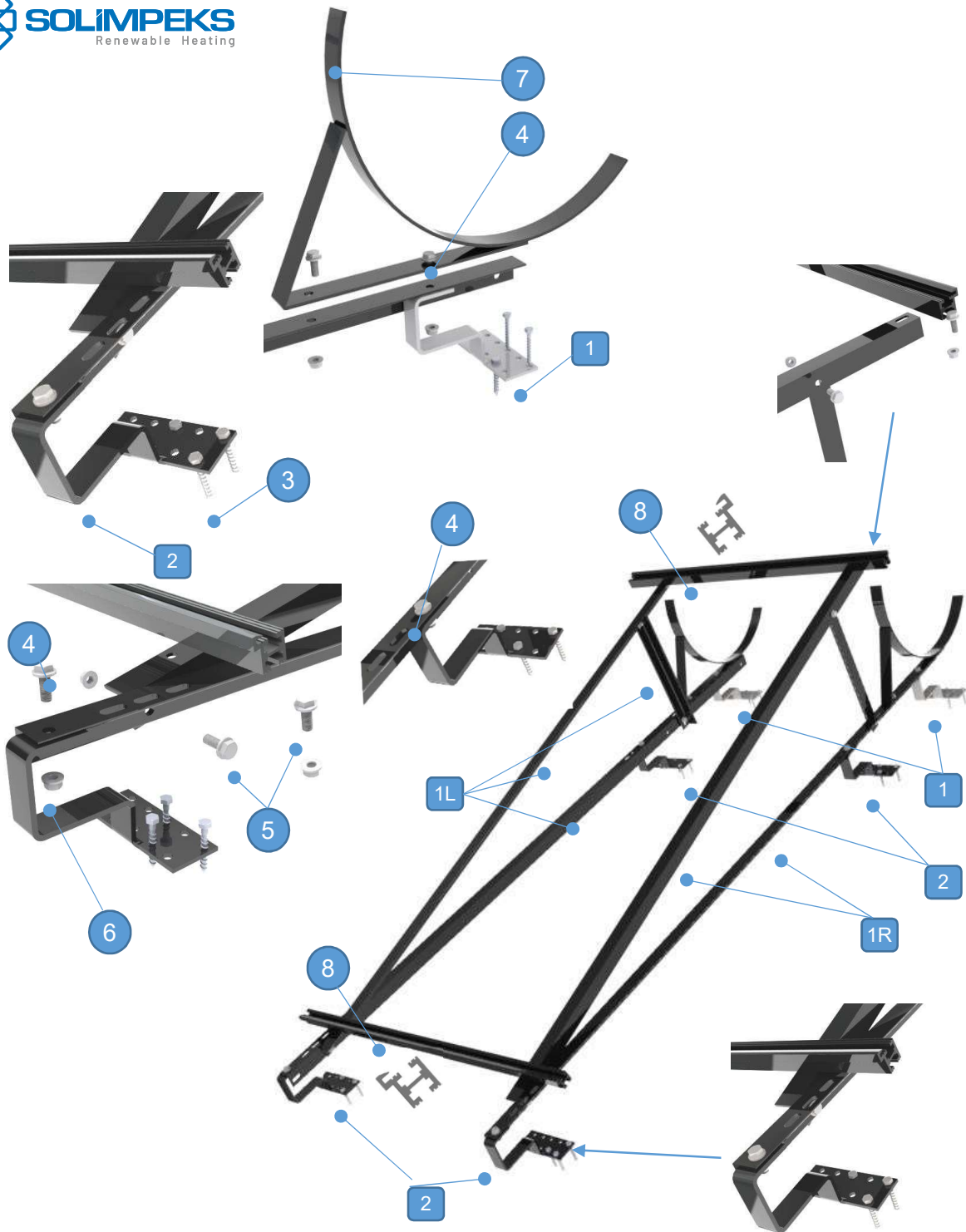

Part Name		Quantity	Part Name		Quantity
1	Support (Stainless Steel)	2	1 L	2415 X 40 X 40 mm	1
2	Support (Black Painted)	4		2060 X 40 X 40 mm	1
3	8 x 60 Wood Screw	18		460 X 40 X 40 mm	1
4	1Screw	6	1 R	2415 X 40 X 40 mm	1
5	Screw	12		2060 X 40 X 40 mm	1
6	Nut	18		460 X 40 X 40 mm	1
7	Tank Holder	2	8	Aluminum Profile	2

3.9 Hydraulic Connections



Photo – 1: Inox Flexible Tube

All the necessary components to connect the solar system could be find inside the support base box.

Two pieces of inox flexible tubes (photo - 1) used to connect the collector with the tank.

The short inox flexible tube is used to connect the up-right

Tube of the collector with the “SOLAR FLOW” inlet which is indicated by a red plastic ring (photo – 2).

The long inox tube is used the connect down-left tube of the collector with the “SOLAR RETURN” which is indicated by a blue plastic ring (photo – 3).

To the rest of the collector’s tubes adapt the brass connector with the plugs.



Photo – 2: Collector Upper-right tube connection



ATTENTION: For the models with two collectors, The collectors must be connected together with the Ø22 X Ø22 unions.

The “HOT WATER” outlet is connected to the house consumption.

3.10 Electrical Component (Optional)

In order to connect the electrical component:

- Unscrew and remove the electrical cover from the solar tank.
- In models that the electrical component is not standard, the tap should be removed.
- Set the thermostat at the desired temperature.

A certified electrician must do all the electrical connections. All the connections should be done according to the diagram.

ATTENTION: The connection must be one on the thermostat NOT directly on the resistance by bypassing the thermostat

The electrical resistance must be connected to the electrical main, via a dual pole cut-off switch. The distance that separates the connections must be AT LEAST 3mm wide.

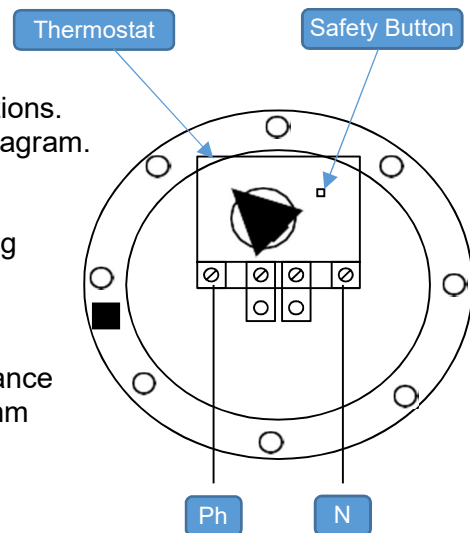

4. Commissioning of the system

4.1 Filling the System

At the upper part of the tank, there are two openings. One of them is for filling the thermal fluid and the other one is the exit of the air during the filling process.

After filling thermal fluid, adapt the safety valve one of the openings and a plug to the other.

The system should be filled at least one liter of Propylene Glycol. This thermal fluid is used to protect the system against freezing.

The system must be always full of thermal fluid. The percentage of anti-freeze in thermal liquid should be:

Percentage (%)	Temperature(°C)
5	-2
10	-4
15	-5
25	-10
30	-14
35	-17
40	-22
50	-32
60	-49
80	-57

The filling of the system must be very slow in order to allow the air to be removed from the closed loop.



This thermal fluid is for solar applications.
 All of its characteristics are indicated for this purpose.



The thermal fluid is non-toxic liquid.



The connection tubes must be well isolated.



Do not use any automatic fill-in system.



The closed loop must not be under pressure.

Before using the system make a final check.

Open all the valves and check for any kind of leakage. Repeat the inspection after 30 mins.



If any leakage appears contact the installer immediately.

4.2 Final Control

To complete the installation, please check the following actions:

DESCRIPTION	OK
Collector's circuit	
Verification of safety valves	
Verification of connection tubes	
Verification of any kind of leakage	
Verification of the electrical connection	
Verification of the stability of the support base	
Verification that all the bolts and nuts are tightly screwed.	

5. Trouble Shooting

Problem Description	Cause	Action
Low efficiency of the system	Low quantity of thermal fluid	Fill-in thermal fluid
	Leakage from the connection tubes	Tight the connectors
	Dirty glass covers	Clean the glass covers
Leakage from the 6 bars safety valve	High main pressure	Install a pressure reducer

6. Annual Performance Calculations

Name of system configuration											TSM 120 L														
Collector name		ALS 1809		No. Collectors		1		Storage name		TSM 120															
Calculated annual results for "solar-only / preheat system"																									
Location	Qd,sh	Daily drawoff				110				Daily drawoff				140				Daily drawoff				170			
		Qd,hw	QL	Qpar	fsol	Qd,hw	QL	Qpar	fsol	Qd,hw	QL	Qpar	fsol												
	MJ/y	MJ/y	MJ/y	MJ/y	%	MJ/y	MJ/y	MJ/y	%	MJ/y	MJ/y	MJ/y	%												
Stockholm SE	-	6100	2391	0	39,2	7750	2553	0	32,9	9450	2677	0	28,3												
WürzburgDE	-	5850	2441	0	41,7	7450	2601	0	34,9	9050	2707	0	29,9												
Davos CH	-	6650	3963	0	59,6	8450	4228	0	50,0	10250	4413	0	43,1												
Athens GR	-	4550	3016	0	66,3	5800	3323	0	57,3	7000	3519	0	50,3												

Name of system configuration											TSM 150 L														
Collector name		ALS 2110		No. Collectors		1		Storage name		TSM 150															
Calculated annual results for "solar-only / preheat system"																									
Location	Qd,sh	Daily drawoff				110				Daily drawoff				140				Daily drawoff				170			
		Qd,hw	QL	Qpar	fsol	Qd,hw	QL	Qpar	fsol	Qd,hw	QL	Qpar	fsol												
	MJ/y	MJ/y	MJ/y	MJ/y	%	MJ/y	MJ/y	MJ/y	%	MJ/y	MJ/y	MJ/y	%												
Stockholm SE	-	6100	2759	0	45,2	7750	2981	0	38,5	9450	3150	0	33,3												
WürzburgDE	-	5850	2845	0	48,6	7450	3067	0	41,2	9050	3216	0	35,5												
Davos CH	-	6650	4547	0	68,4	8450	4912	0	58,1	10250	5169	0	50,4												
Athens GR	-	4550	3387	0	74,4	5800	3813	0	65,7	7000	4084	0	58,3												

Name of system configuration											TSM 200 L														
Collector name		ALS 2512		No. Collectors		1		Storage name		TSM 200															
Calculated annual results for "solar-only / preheat system"																									
Location	Qd,sh	Daily drawoff				170				Daily drawoff				200				Daily drawoff				250			
		Qd,hw	QL	Qpar	fsol	Qd,hw	QL	Qpar	fsol	Qd,hw	QL	Qpar	fsol												
	MJ/y	MJ/y	MJ/y	MJ/y	%	MJ/y	MJ/y	MJ/y	%	MJ/y	MJ/y	MJ/y	%												
Stockholm SE	-	9450	3627	0	38,4	11100	3768	0	33,9	13850	3938	0	28,4												
WürzburgDE	-	9050	3735	0	41,3	10650	3877	0	36,4	13300	4044	0	30,4												
Davos CH	-	10250	5924	0	57,8	12050	6159	0	51,1	15050	6440	0	42,8												
Athens GR	-	7000	4635	0	66,2	8250	4924	0	59,7	10350	5281	0	51,0												

Name of system configuration											TSM 300 L														
Collector name		ALS 2110		No. Collectors		2		Storage name		TSM 300															
Calculated annual results for "solar-only / preheat system"																									
Location	Qd,sh	Daily drawoff				250				Daily drawoff				300				Daily drawoff				400			
		Qd,hw	QL	Qpar	fsol	Qd,hw	QL	Qpar	fsol	Qd,hw	QL	Qpar	fsol												
	MJ/y	MJ/y	MJ/y	MJ/y	%	MJ/y	MJ/y	MJ/y	%	MJ/y	MJ/y	MJ/y	%												
Stockholm SE	-	13850	6153	0	44,4	16650	6491	0	39,0	22200	6909	0	31,1												
WürzburgDE	-	13300	6376	0	47,9	15950	6695	0	42,0	21300	7115	0	33,4												
Davos CH	-	15050	9947	0	66,1	18050	10466	0	58,0	24100	11185	0	46,4												
Athens GR	-	10350	7719	0	74,6	12400	8347	0	67,3	16500	9159	0	55,5												

7. Warranty



SOLIMPEKS SOLAR CORP.

Fevzi Çakmak Mah. 10753 Sok. No : 3
Karatay,42050 Konya TURKEY

T «Phone»
F +90 (332) 444 06 08
info@solimpeks.com

www.solimpeks.com

SOLIMPEKS LIMITED WARRANTY for Solar Thermal Collectors and Thermosiphon Systems

Models Covered

This limited warranty is provided by Solimpeks Solar Corp. (Solimpeks) and covers all Solar Flat Plate Collectors and Thermosiphon systems produced by Solimpeks (hereinafter referred to as "Solar Collector"). This warranty is provided to the original purchaser of the Solar Collector as long as the Solar Collector remains installed at its original place of installation.

Warranty Coverage

Ten Year –Limited Warranty Solimpeks warrants that the Solar Collector shall remain free from defects in workmanship and materials for ten year

Six Year –Limited Warranty Solimpeks warrants that the TSM Thermosiphon Systems shall remain free from defects in workmanship and materials for six year from the date of original installation provided they are installed and properly maintained by a qualified heating contractor and the other conditions of this warranty are met. If Solimpeks determines that the Solar Collector and Thermosiphon systems or any part of the Solar Collector or Other Components has a defect in workmanship or materials, Solimpeks, at its option, will repair or replace the defective part. Labor charges are not included.

Items Not Covered

This limited warranty does not cover the following circumstances:

- 1.Solar Collectors Thermosiphon systems installed in a building other than a one or two family residential dwelling, unless individual Solar Collectors are installed for each dwelling unit.
 2. Components or parts not provided by Solimpeks.
 3. Serviceable items and normal maintenance as required per the Installation Manual.
 4. The workmanship of any installer. Solimpeks disclaims and does not assume any liability of any nature for unsatisfactory performance caused by improper installation, repair or maintenance.
 5. Any labor or material costs for removal, reinstallation, repair and replacement of the defective component or part unless otherwise provided above.
 6. Transportation to Solimpeks, if necessary.
 7. Damage caused by excessive temperatures or pressures (when solar water heater will not be used more than 15 days without covering the panels.), fuel or gas explosion, electrochemical reaction, water and air impurities (rust, lime etc occurred by impure water* can cause malfunction of the collector, so the system), electrical failures, flooding or acts of God.
- * Recommended Pure Water Quality : Solimpeks TSM water heater is suitable for use with water with a total dissolved solid content less than 1,000 ppm and for which the total hardness does not exceed 200 ppm CaCO₃.
8. Any damage or failure resulting from the introduction of harmful chemicals, caustic fluids, or liquids detrimental to copper tubing, including but not limited to improperly applied or maintained heat transfer fluids or chlorinated pool or spa water.
 9. Except as set forth above related to Other Components, of the solar system that are part of the solar system into which the Solar Collector is incorporated that are not Solimpeks products are not covered by this

info@solimpeks.com, www.solimpeks.com

warranty and are limited to the warranty of the manufacturer of such components. In order to file a claim for warranty you should contact the manufacturer.

10. Shipping charges, delivery expenses or administrative fees incurred by the purchaser in repairing or replacing the Solar Collector

Conditions of Warranty

The warranty herein is void under the following circumstances:

1. Any Solar Collector that is installed and operated in an application other than medium temperature (110 - 194 F) water heating.
2. Failure or malfunction resulting from improper or negligent operation, accident, abuse, freezing, misuse, unauthorized alteration or improper installation, repair or maintenance. See the Owner's Manual for installation and maintenance information.
3. Failure or malfunction resulting from any condensation or similar occurrence resulting from the intrusion of moisture into the collector.
4. Failure or malfunction resulting from the introduction of harmful chemicals, caustic fluids, or liquids detrimental to copper tubing, including improperly applied or maintained heat transfer fluids or chlorinated pool or spa water.
5. Any Solar Collector that is installed and operated with anti-freeze that has not been approved by Solimpeks.
6. Work performed without prior authorization or approval and without authorization/requisition number and without proper documentation verifying compliance with above terms.

Limited Warranty

Other than the obligations of Solimpeks expressly set forth hereon, Solimpeks disclaims all warranties, express or implied, including but not limited to any implied warranties of merchantability or fitness for a particular purpose. Solimpeks' sole obligation with respect to the solar collector and purchaser's exclusive remedies are set forth in the foregoing limited warranty. Solimpeks shall not be liable for any indirect, punitive, incidental, special, consequential or similar damages including, without limitation, injury or damage to persons or property or damages for loss of use, lost profits, inconvenience or loss of time.

Note that any repaired or replaced product will be warranted for only the unexpired term of the original warranty.

Some states do not allow the exclusion of limitation of damages, or limitations on how long an implied warranty lasts, so the above limitations and exclusions may not apply to you.

Warranty Claims Process

If you have a warranty claim you should notify the heating contractor who installed your Solar Collector and ask that the contractor notify the distributor from whom the contractor purchased the Solar Collector. If this action is not possible or you don't receive a response, contact Solimpeks Solar Corp., Fevzi Çakmak Mah. 10753 Sok. No : 3 Karatay, 42050 Konya TURKEY. To process your claim, you will need a copy of your original invoice or other proof of purchase and documentation showing the original installation date and location. The alleged defective components or parts must be returned to Solimpeks in accordance with Solimpeks procedure then in force for handling goods returned for the purpose of inspection to determine cause of failure (contact Solimpeks if you have questions regarding the return process). If Solimpeks determines that the returned components and/or parts are defective and that this warranty applies, Solimpeks will furnish the repaired or replacement components and/or parts to an authorized Solimpeks distributor who, in turn, will forward the components and/or parts to the heating contractor who installed your solar system.

Effective for sales on or after 1/1/2011.